



Series L



Modular Connectors

MODULAR CONNECTORS

Superior Contact Design

Hypertac is an advanced contact design that satisfies performance requirements previously considered impossible. The shape of the contact sleeve is formed by wires strung at an angle to the socket's axis. When the pin is inserted into this sleeve, the wires stretch around it, providing a number of linear contact paths.

The superior design of the Hypertac contact system offers several features and benefits

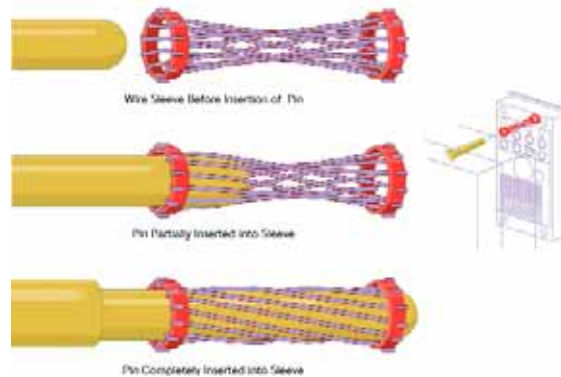

Feature

Low Insertion/Extraction Forces

The controlled angle of the socket wires allows tight control of the pin insertion and extraction forces. The spring wires are smoothly deflected to make line contact with the pin.

Long Contact Life

The smooth and light wiping action minimizes wear on the contact surfaces. Hypertac Contacts perform up to 100,000 insertion/extraction cycles with no degradation in performance.

Lower Contact Resistance

Hypertac multiple line contacts provide far greater contact area than other contacts of comparable size. The wiping action of the wires insures a clean and polished contact surface. Tests have shown Hypertac contacts have about half the resistance of conventional contact designs.

Higher Current Ratings

The design parameters of the Hypertac contact may be modified for any special requirement. For example, the number of wires can be increased in order to distribute the contact area over a larger surface of the mating pin. Thus, the high current carried by each wire because of its intimate line contact, can be multiplied many times.

Immunity to Shock & Vibration

The low mass and low inertia of the wires enable them to follow the most abrupt or extreme excursions of the pin without the loss of contact. The contact area extends 360° around the pin and is uniform over its entire length. The 3 dimensional symmetry of the Hypertac contact design guarantees electrical continuity regardless of the direction or intensity of external or internal forces.

Benefit

High Density Interconnect Systems

Significant reductions in size and weight of sub-system designs can be achieved by employing Hypertac high density connectors with a large number of contacts that do not require additional hardware to overcome mating and un-mating forces.

Low cost of ownership

Hypertac is ideal for applications that require frequent connector mating cycles, thus eliminating the burden and cost of having to replace the connector or the entire subsystem.

Low Power Consumption

The lower contact resistance of the Hypertac contact results in a lower voltage drop across the connector which reduces the power consumption and heat generation within the system.

Maximum Contact Performance

The lower contact resistance of the Hypertac reduces heat build up; therefore Hypertac contacts are able to handle far greater current in smaller contact assemblies without the detrimental effects of high temperature.

Reliability Under Harsh Environmental Conditions

Harsh environmental conditions require connectors that will sustain their electrical integrity even under the most demanding conditions such as shock and vibration. Hypertac provides unmatched stability in demanding environments when failure is not an option.

Modular Connectors

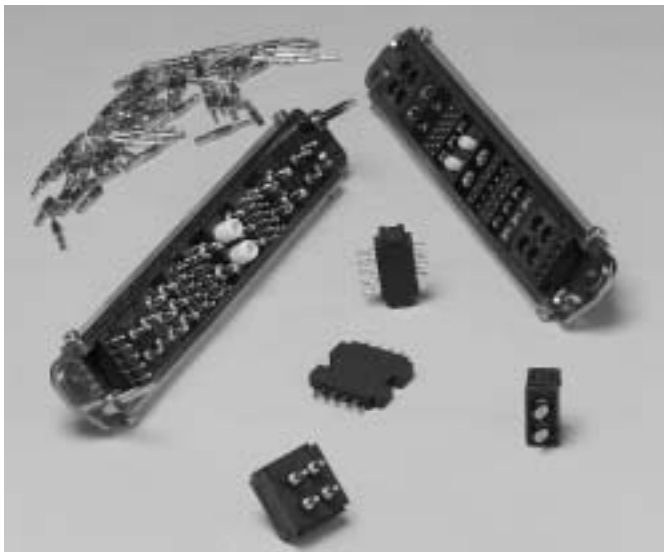

Hypertac® modular connectors employ a do-it-yourself system based on the building block principle.

They offer a wide variety of combinations available in a single connector frame. Thus, the user is capable of selecting the connector that fulfills the exact requirements with off-the-shelf components.

One of the many advantages of the Hypertac® contact used is its low extraction and insertion forces. In this application it enables the user to assemble large numbers of contacts into a connector which is still able to mate and unmate smoothly and easily

The modular connectors series can be built up for the following:

- Rack and panel applications
 - Standard
 - With jackscrews
 - With floating mounting
- Cable applications
 - Hooded with rounded or flat cable clamps
 - With jack screws
- Program applications

The system is composed of two basic elements: the modules and the frames.

1. The modules are the connector elements of the system. Various types of contacts are available, such as signal, power, coaxial, high voltage, etc. These contacts are mounted in small plastic blocks. Crimp contacts are also available in plastic blocks that can be mounted individually or together into the frame. The width of each module block is designated in units.

The modules have fixed contacts with:

2 contacts	@ 50 amps	(type M)
2 contacts	@ 25 amps	(type C)
2 contacts	shielded	(type E)
2 contacts	high voltage	(type H)
2 contacts	@ 200 amps	(type I)
2 contacts	fiber optic	(type Y)
3 contacts	@ 15 amps	(type B)
4 contacts	@ 15 amps	(type N)
5 contacts	@ 8 amps	(type A)
9 contacts	@ 5 amps	(type Q)
9 contacts	@ 8 amps	(type G)
17 contacts	@ 5 amps	(type D)

Coaxial contacts:

2 contacts	(type J)
2 contacts	(type K)
3 contacts	(type L)

Removable contacts:

2 contacts	@ 25 or 50 amps	(type Z)
3 contacts	@ 15 amps	(type W)
5 contacts	@ 8 amps	(type T)
5 contacts	@ 8 amps	(type X)
17 contacts	@ 8 amps	(type O)
30 contacts	@ 3 amps	(type LW)

2. They range from a basic frame consisting of 2 side rails and 2 end caps to more complex versions with jack screws, hoods, cable clamps, etc. All frames are available in numerous lengths to conform to almost any combination of modules. With the modular Series, specially designed connectors can be purchased quickly and inexpensively, eliminating the extra cost and delay of custom tooling.

Index

General Notes	3
Series	4
“A” Series	4
“B” Series	4
“H” Series	4
“J” Series	5
“JS” Series	6
“BV” Series	7
“JV” Series	8
“V” Series	9
Modules	13
Type “LW” Element (ø 0.60 removable contacts-clip)	13
Type “Q” Element (ø 1.00 contacts)	14
Type “D” Element (ø 1.20 contacts)	15
Type “A” Element (ø 1.50 contacts)	16
Type “G” Element (ø 1.50 contacts)	17
Type “X/X1” Element (ø 1.50 removable contacts-cloc)	18
Type “T” Element (ø 1.50 removable contacts-clip)	20
Type “N” Element (ø 2.00 contacts)	21
Type “B” Element (ø 2.50 contacts)	22
Type “W” Element (ø 2.50 removable contacts-cloc)	23
Type “C and M” Element (ø 3.50 contacts)	24
Type “Z” Element (ø 3.50 removable contacts)	25
Type “I” Element (ø 6.00 contacts)	27
Type “E” Element (shielded contacts)	28
Type “H” Element (high voltage contacts)	29
Type “L” Element (coaxial contacts)	30
Type “J” Element (coaxial contacts)	31
Type “K” Element (coaxial contacts)	32
Type “Y” Element (for fiber optic couplers)	33
Type “O” Jackscrew (PLUG side connector)	34
Type “O” Jackscrew (RECEPTACLE side connector)	34
Type “2” Jackscrew (PLUG side connector)	35
Type “2” Jackscrew (RECEPTACLE side connector)	35
Panel Cutout	36

General Notes

Progression and sum of contact elements (for elements see details page 13÷33)

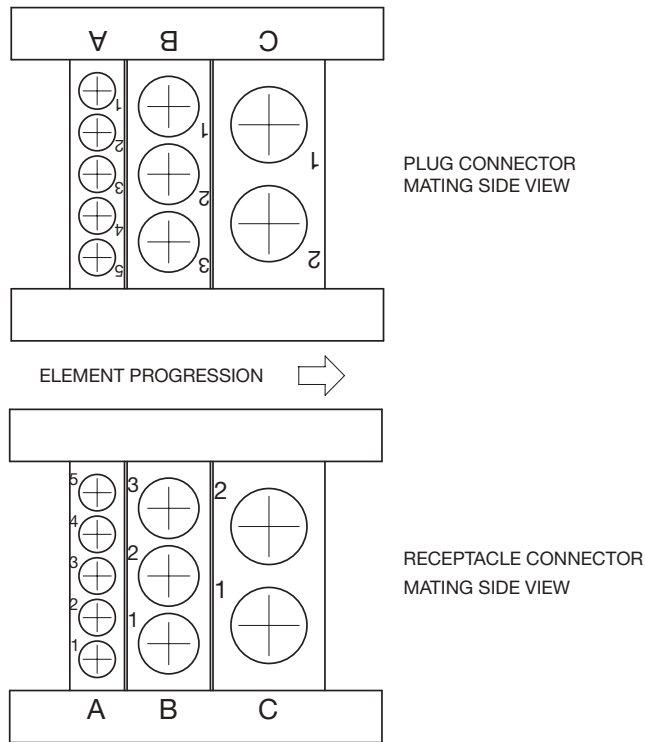

- The progression of the contact element is always from left to right with the element orientation (position numbering) as in drawing

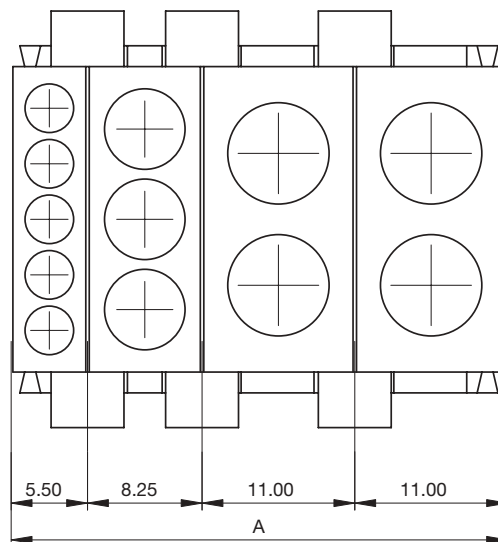

Therefore a “step” is defined as the length used by each assembled element.

- An elementary step is defined as 5.50 mm
- The letter “A” is the sum of the dimensions of the contact elements.

Contact Plating

T Reference:

Functional part (Mating Area): 0,25 µm Gold per ASTM B-488 type II Grade C on 2 µm Ni per QQ N-290
 Termination area: 0,15 µm Gold per ASTM B-488 type II Grade C on 2 µm Ni per QQ N-290

H Reference:

Functional part (Mating Area): 1,27 µm Gold per ASTM B-488 type II Grade C on 2 µm Ni per QQ N-290
 Termination area: 0,15 µm Gold per ASTM B-488 type II Grade C on 2 µm Ni per QQ N-290

Dimensions are in mm

“A” Series

Application: Rack and Panel without guiding hardware

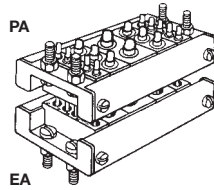
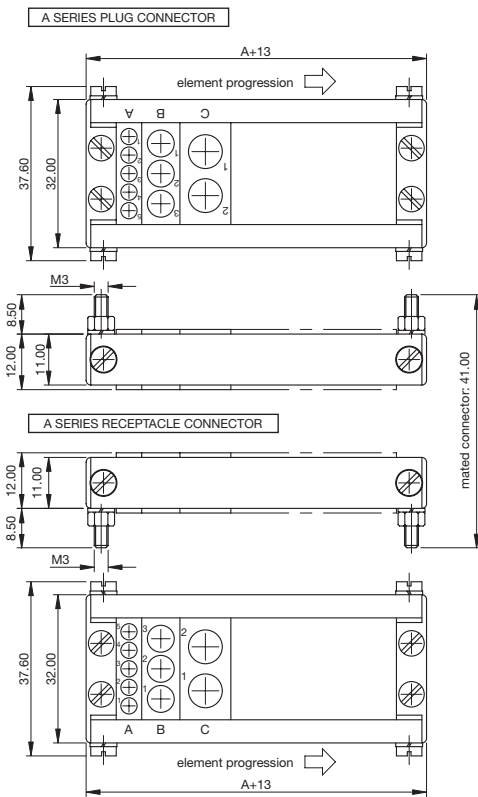

ORDERING CODE

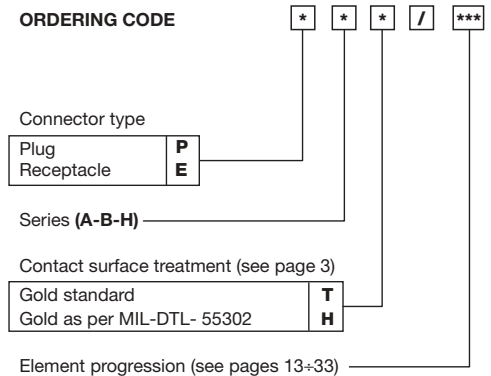

Connector type

Plug	P
Receptacle	E

Series **(A-B-H)**

Contact surface treatment (see page 3)

Gold standard	T
Gold as per MIL-DTL- 55302	H

Element progression (see pages 13+33)

ex.: PAT/3Am-2Dm

(A Series plug with 3 elements type Am, two elements type Dm, surface treatment T)

“B” Series

Application: Rack and Panel with guiding hardware

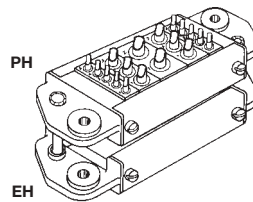
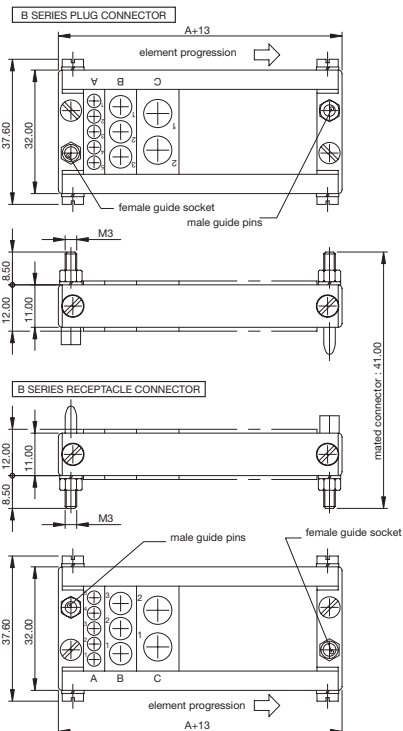

“H” Series

Application: Rack and Panel with guiding floating hardware

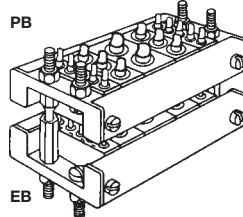
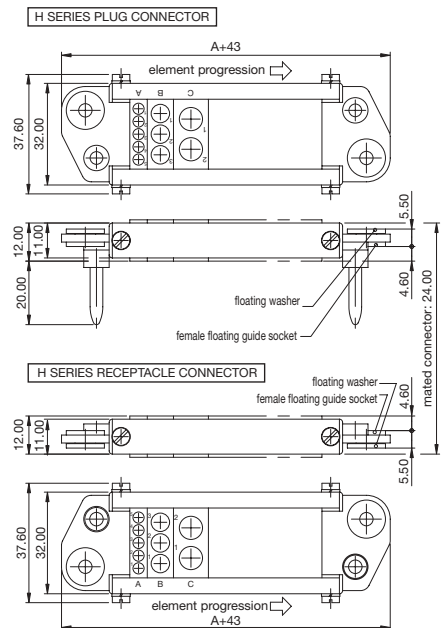

Dimensions are in mm

“J” Series

Application: Cable interface top entry, quick disconnect device

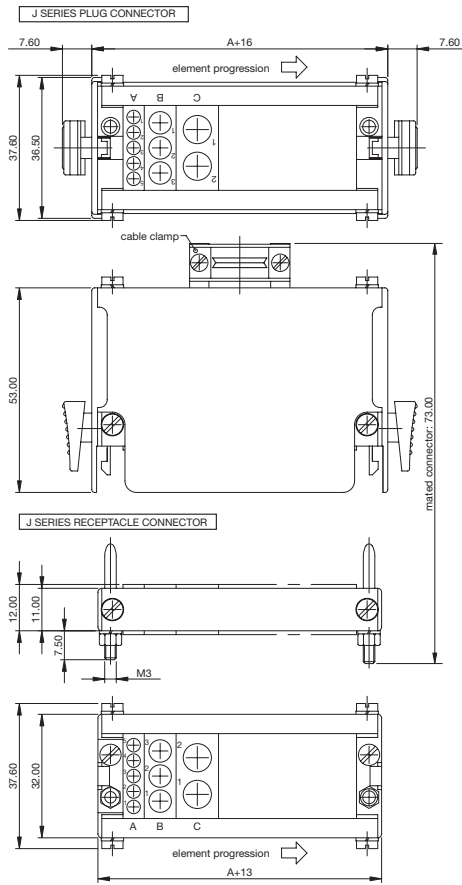

SPECIAL		
cable clamp	length (size A+16)	
ø 10	≥ 29.75	≤ 35.25
ø 15	≥ 35.25	≤ 40.75
ø 20	≥ 40.75	≤ 46.25
ø 24	49.00	

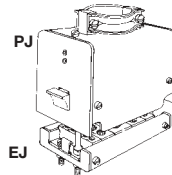

ORDERING CODE

*	J	*	/	***	/	**
Connector type						
Plug	P					
Receptacle	E					
Series						
Contact surface treatment (see page 3)						
Gold Standard	T					
Gold as per MIL-DTL- 55302	H					
Element progression (see pages 13+33)						
Cable clamp (only for Plug connector)						
Circular cable clamp ø 10	10					
Circular cable clamp ø 15	15					
Circular cable clamp ø 20	20					
Circular cable clamp ø 24	24					

ex.: PJT/3Am-2Dm/10

(J Series plug with 3 elements type Am, two elements type Dm, circular cable clamp ø 10, surface treatment T)

“JS” Series

Application: Cable interface on H SERIES

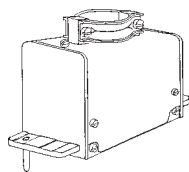
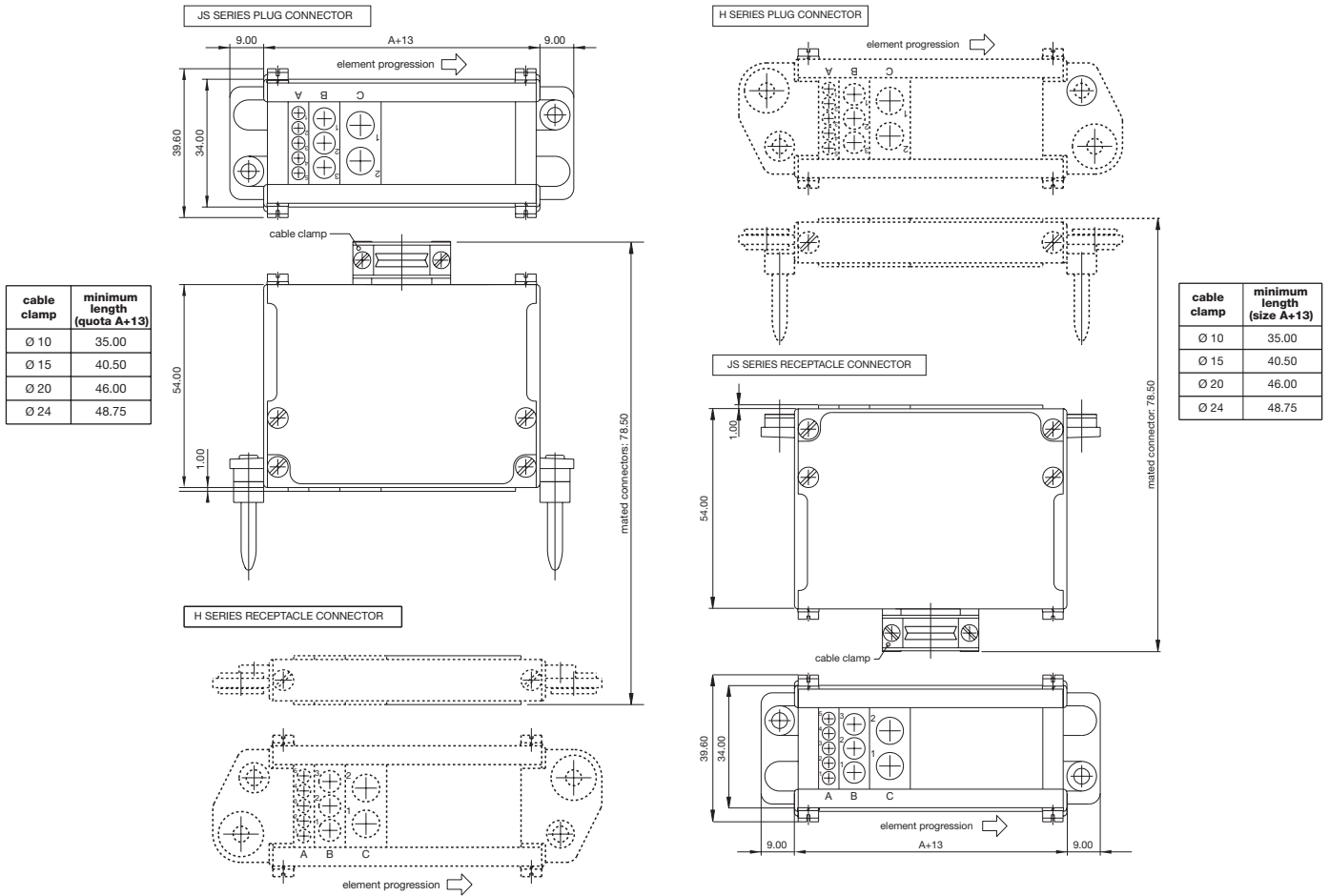

ORDERING CODE

* JS * / *** / ***

Connector type

Plug **P**
Receptacle **E**

Series

Contact surface treatment (see page 3)

Gold Standard **T**
Gold as per MIL-DTL- 55302 **H**

Element progression (see pages 13+33)

Cable clamp

Cable clamp size ø 10	10
Cable clamp size ø 15	15
Cable clamp size ø 20	20
Cable clamp size ø 24	24

ex.: PJST/3Am-2Dm/10

(J Series plug with 3 elements type Am, two elements type Dm, circular cable clamp ø 10, surface treatment T)

“BV” Series

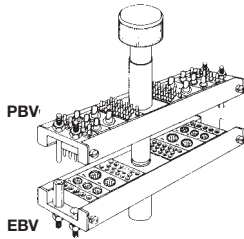

Application: Cable interface, without shell, screw locking device

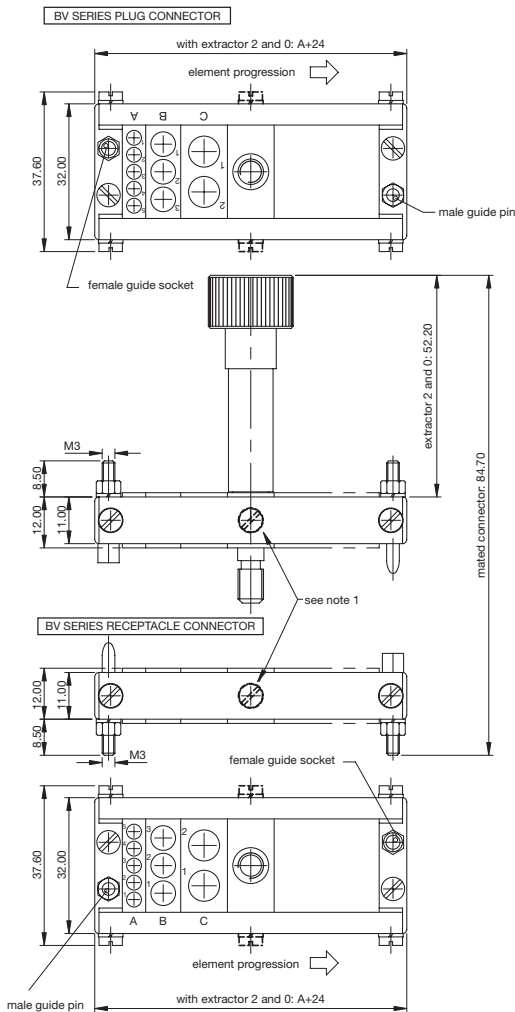

Notes:

- 1) Type 2 and 0 extractor: Length (size A+24) < 101mm without extractor holding screws; > 103.75mm. with screws.
- 2) To simplify the drawing only type 2 extractor has been shown

ORDERING CODE

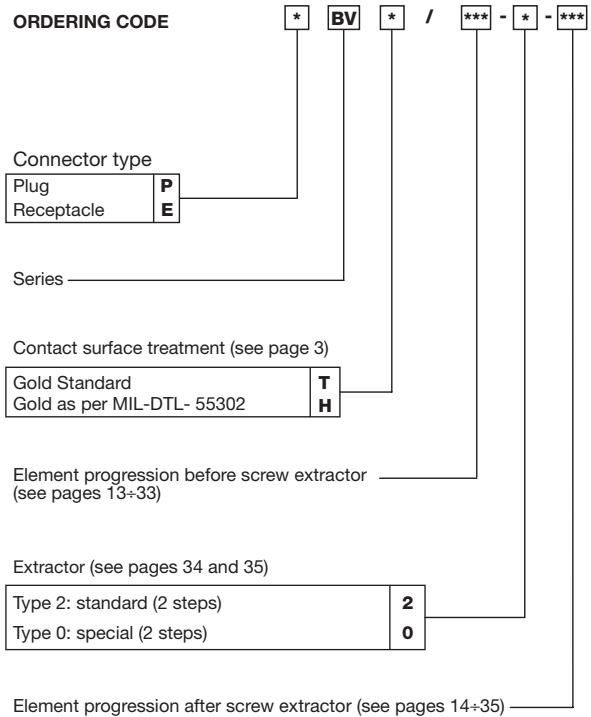

ex.: PBVT/3Am-2-3Am
 (BV Series plug with 3 elements type Am, Type 2 extractor, 3 elements type Am, contact surface treatment T)

“JV” Series

Application: Cable interface with side and top clamps

cable clamp	Choice B minimum size of connector	
	(A+27.00)	(A+32.50)
Ø 10	76.50	82.00
Ø 15	87.50	93.00
Ø 20	98.50	104.00
Ø 24	104.00	109.50

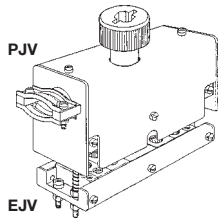

JV SERIES PLUG CONNECTOR

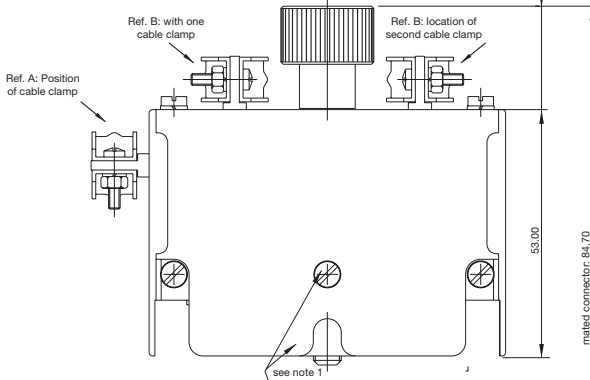
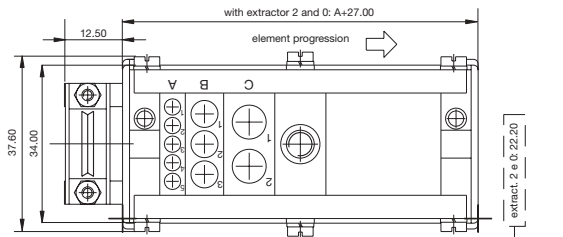

JV SERIES RECEPTACLE CONNECTOR

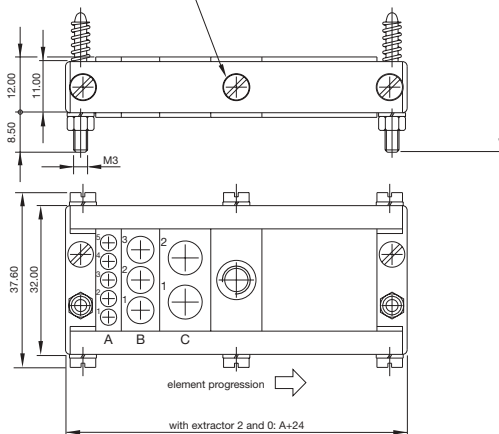

NOTES:

- 1) Type 2 and 0 extractors: Length (size A+27) < 104mm without extractor holding screws and eyelets on cover; >106.75mm. with screws and eyelets on cover.
- 2) To simplify the drawing only type 2 extractor has been shown

ORDERING CODE

	*	JV	*	/	***	-	*	-	***	/	*	***
Connector type												
Plug		P										
Receptacle		E										
Series												
Contact surface treatment (see page 3)												
Gold Standard		T										
Gold as per MIL-DTL- 55302		H										
Element progression before screw extractor (see pages 13+33)												
Extractor (see pages 34 and 35)												
Type 2: standard (2 steps)											2	
Type 0: special (2 steps)											0	
Element progression after screw extractor (see pages 13+33)												
Position of cable clamp (only for plug)												
Cable clamp on side											A	
Cable clamp/s on cover											B	
Quantity and diameter of cable clamp (only for plug)												
N° 1 cable clamp ø 10												110
N° 1 cable clamp ø 15												115
N° 1 cable clamp ø 20												120
N° 1 cable clamp ø 24												124
N° 2 cable clamp ø 10												210
N° 2 cable clamp ø 15												215
N° 2 cable clamp ø 20												220
N° 2 cable clamp ø 24												224

ex.: PJVT/3Am-2-3Am/B215

(JV Series plug with 3 elements type Am, type 2 extractor, 3 elements type Am, two cable clamps ø 15 on cover, contact surface treatment T)

“V” Series

Application: Cable interface with plastic shell

ORDERING CODE * **V*** * / *** - * - *** / * ** ***

Connector type
 Plug **P**
 Receptacle **E**

Series
 Without coding **V0**
 With coding **V1**

Contact surface treatment (see page 3)
 Gold Standard **T**
 Gold as per MIL-DTL- 55302 **H**

Element progression before screw extractor (see pages 13+33)

Extractor (see pages 34 and 35)
 Type 2: standard (2 steps) **2**
 Type 0: special (2 steps) **0**

Element progression after screw extractor (see pages 13+33)

Standard lengths (sizes shown are those of covers)

	PROGRESSION (in steps: 1 step = 5.50mm.) extr. 2 or 0	
84.20 mm.	5-2-5	a
100.70 mm.	6.5-2-6.5	b
100.70 mm.	7-2-6	c
111.70 mm.	8-2-7	d
128.20 mm.	9-2-9	e
139.20 mm.	10-2-10	f

Quantity and size of cable clamp (only for plug)

n°1 standard adjustable cable clamp	10
n°2 standard adjustable cable clamps	20
n°1 3/4" GAS cable clamp	11
n°2 3/4" GAS cable clamps	21
n°1 1" GAS cable clamp	12
n°2 1" GAS cable clamps	22

V1 Series: Coding
 Leave blank if standard F6 coding is required

ex.: PV1T/5Am-2-5Am/a10B4

Series V1 plug receptacle (with coding), 5 elements type Am, type 2 extractor, 5 elements type Am, length a (84.20mm.), one adjustable cable clamp, contact surface treatment T, B4 coding.

“V” Series

V0 SERIES PLUG CONNECTOR

Length indication	Size L	Progression extr. 2 or 0
a	84.20	5-2-5
b	100.70	6.5-2-6.5
c	100.70	7-2-6
d	111.70	8-2-7
e	128.20	9-2-9
f	139.20	10-2-10

V0 SERIES RECEPTACLE CONNECTOR

Length indication	Size L	Progression extr. 2 or 0
a	79.00	5-2-5
b	95.50	6.5-2-6.5
c	95.50	7-2-6
d	106.50	8-2-7
e	123.00	9-2-9
f	134.00	10-2-10

V0 SERIES PLUG CONNECTOR

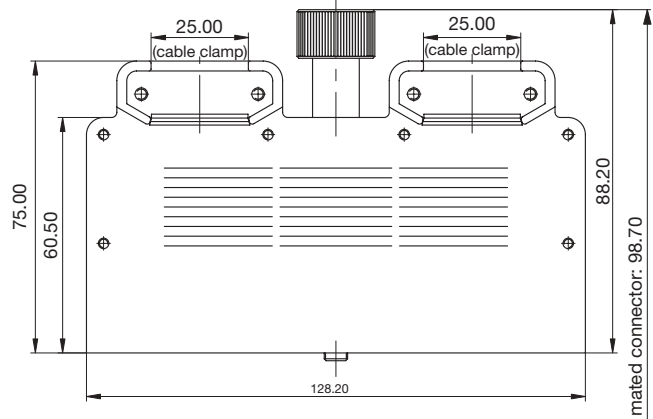
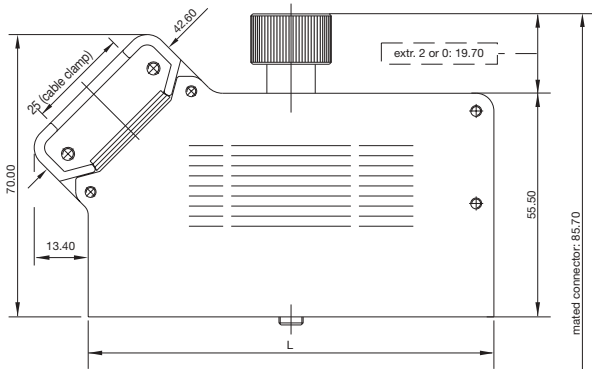
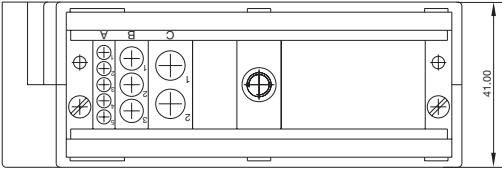
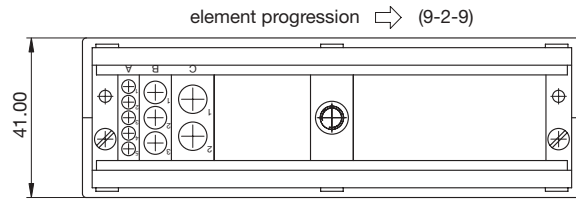

V0 SERIES RECEPTACLE CONNECTOR

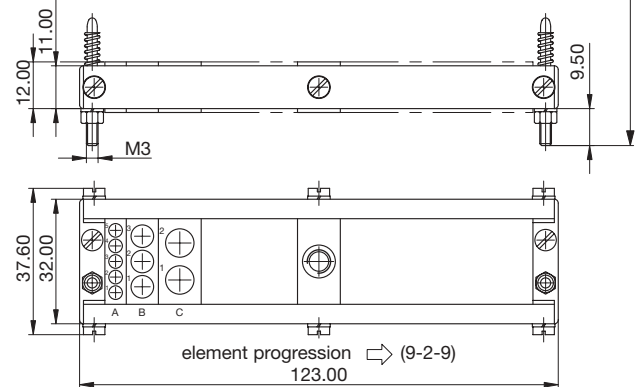

V0 SERIES RECEPTACLE CONNECTOR

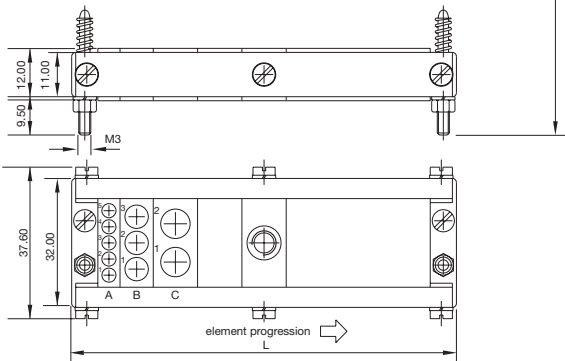

NOTES:

- 1) The progression is meant as number of steps (1 step= 5.50mm.).
- 2) Only type 2 extractor can be mounted.

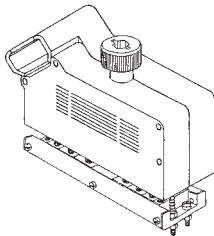

NOTES:

- 1) The progression is meant as number of steps (1 step= 5.50mm.)
- 2) Connectors with lengths "a-b-c" are supplied without screws or gloves for holding extractor.
- 3) As an example, only connector length "b" with extractor type 2 is shown

“V” Series

“V1” SERIES CONNECTOR: PLUG CODING SCHEME

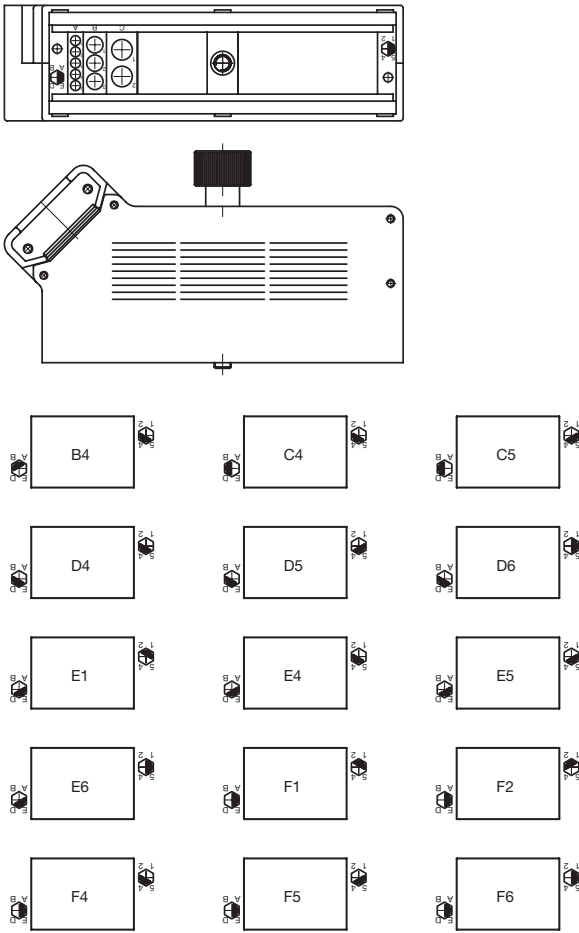

- N° 36 possible options of which 15 only are recommended (see above)
 The remaining 21 options (A1-A2-A3-A4-A5-A6-B1-B2-B3-B5-B6-C1-C2-C3-C6-D1-D2-D3-E2-E3-F3) do not codify the connector.
 - As an example, only the plug connector with one cable clamp is shown.

“V1”: SERIES CONNECTOR: RECEPTACLE CODING SCHEME

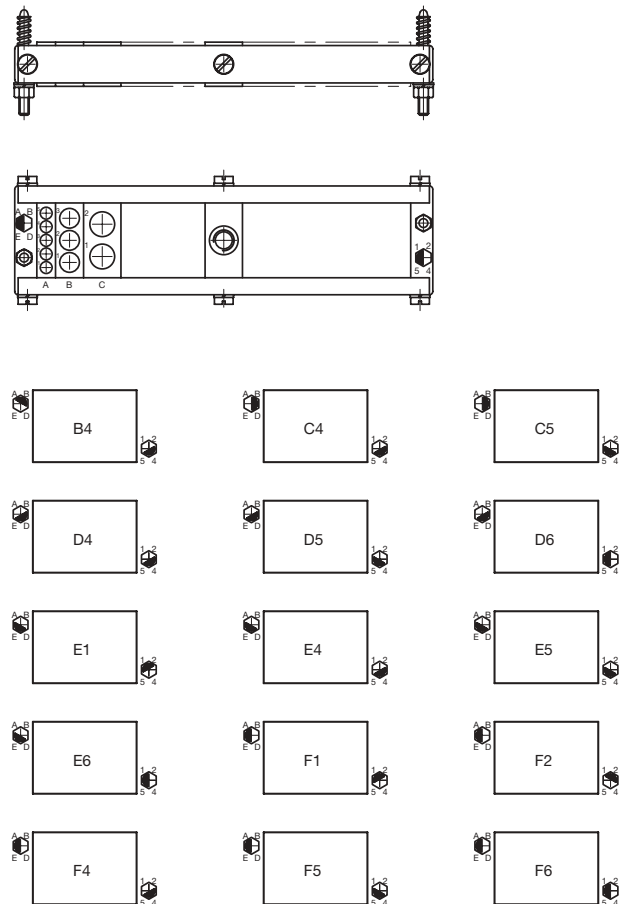

- N° 36 possible options of which 15 only are recommended (see above)
 The remaining 21 options (A1-A2-A3-A4-A5-A6-B1-B2-B3-B5-B6-C1-C2-C3-C6-D1-D2-D3-E2-E3-F3) do not codify the connector.

GAS CABLE CLAMPS

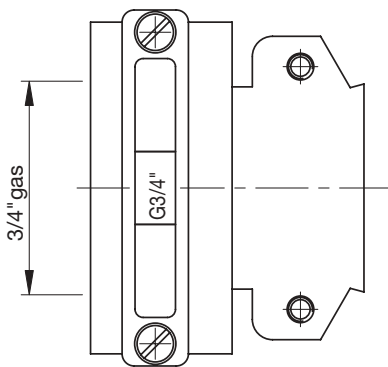

TYPE 1 CABLE CLAMP

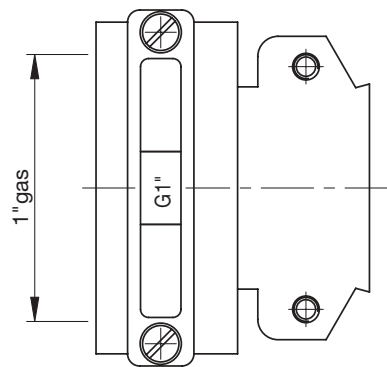

TYPE 2 CABLE CLAMP

Type "LW" element (ø 0.60 removable contacts-clip)

2 STEPS: 11mm.

(assembly with spacer clips)

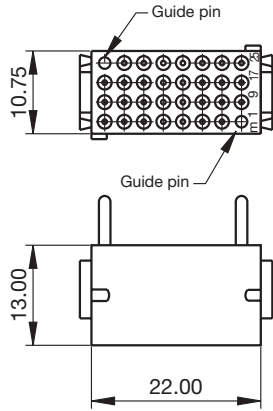

INSULATING BLOCK: **Ref. LWMHT**

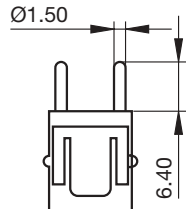

Ref. LWMR
(AWG 28÷22)

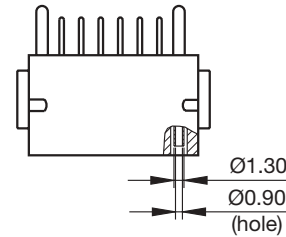

Ref. LWMS
(AWG 22)

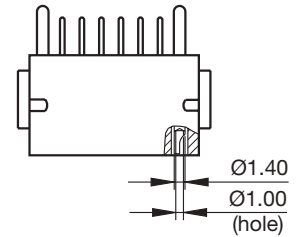

CONTACTS ARE SUPPLIED NOT ASSEMBLED

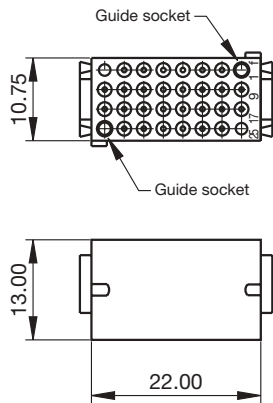

INSULATING BLOCK: **Ref. LWFHT**

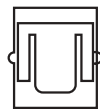

Ref. LWFR
(AWG 28÷22)

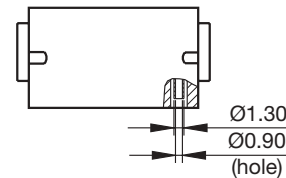

Ref. LWFS
(AWG 22)

CONTACTS ARE SUPPLIED NOT ASSEMBLED

General specification

Contact Retention ¹⁾	>25 N
Mating & Unmating Force (Module) ²⁾	<25 N
Weight (M/F)	9.2/13.2 g
Contact Resistance (1mA) ³⁾	<5 mΩ
Current Rating (25°C) ⁶⁾	4 A
Current rating at 95°C	3 A
UL Rating	-
Dielectric Withstanding Voltage ⁴⁾	
- Cont/ Cont	1650 V r.m.s.
- Cont/Hardware	1650 V r.m.s.
Insulation Resistance (500 V d. c.) ⁵⁾	
- Cont/ Cont	>10 ⁶ MΩ
- Cont/Hardware	>10 ⁶ MΩ
Insulator's Material	PPS

Accessories/spare contact ref.

Insertion Tool	S/MONT/1/0060
Extraction Tool	S/DEM/6/0060
Crimping Tool	AFM8
Positioner	S/S/1/0060
Spare contact Pin Ref.	12548 ref. LWMR 12550 ref. LWMS
Spare contact Socket Ref.	12512 ref. LWFR 12514 ref. LWFS

1) ref. MIL -STD-1344 Method 2007
 2) ref. MIL -STD-1344 Method 2013.1
 3) ref. MIL -STD-1344 Method 2004
 4) ref. MIL -STD-1344 Method 3001.1
 5) ref. MIL -STD-1344 Method 3003.1
 6) ref. I.E.C. 512-3 Test 5b (t_r= 125°C/10xSQRT (125-T))

Type "Q" element (ø 1.00 contacts)

1 STEP: 5.50mm.

(assembly without spacer clips)

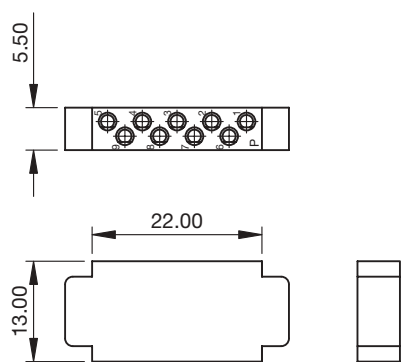

INSULATING BLOCK: **Ref. QHP**

NOTES:

- The codes are for elements mounted on plug connectors.
- For spare elements the code must be followed by the letter P ex. QHP, QmP, QfP

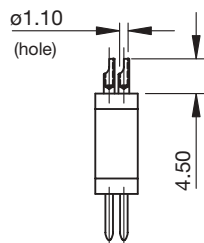

Ref. Qm

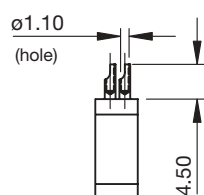

Ref. Qf

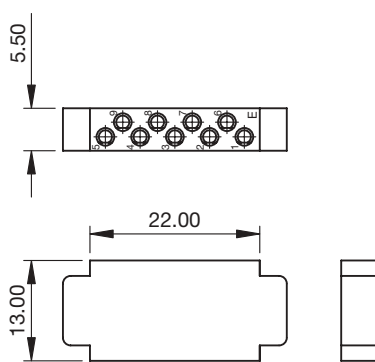

INSULATING BLOCK: **Ref. QHE**

NOTES:

- The codes are for elements mounted on receptacle connectors.
- For spare elements the code must be followed by the letter E ex. QHE, QmE, QfE

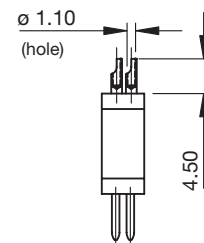

Ref. Qm

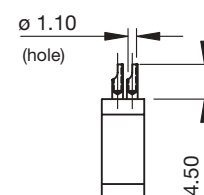

Ref. Qf

General specification

Contact Retention ¹⁾	>70 N
Mating & Unmating Force (Module) ²⁾	<15 N
Weight (M/F)	5.2/6.2 g
Contact Resistance (1mA) ³⁾	<2.5 mΩ
Current Rating (25°C) ⁶⁾	9 A
Current rating at 95°C	5 A
UL Rating	8 A
Dielectric Withstanding Voltage ⁴⁾	
- Cont/ Cont	2000 V r.m.s.
- Cont/Hardware	1500 V r.m.s.
Insulation Resistance (500 V d. c.) ⁵⁾	
- Cont/ Cont	>10 ⁶ MΩ
- Cont/Hardware	>10 ⁶ MΩ
Insulator's Material	DAP

1) ref. MIL -STD-1344 Method 2007
 2) ref. MIL -STD-1344 Method 2013.1
 3) ref. MIL -STD-1344 Method 2004
 4) ref. MIL -STD-1344 Method 3001.1
 5) ref. MIL -STD-1344 Method 3003.1
 6) ref. I.E.C. 512-3 Test 5b (tr= 125°C/10xSQR (125-T))

Type "D" element (ø 1.20 contacts)
2 STEPS: 11.00mm.

(assembly with spacer clips)

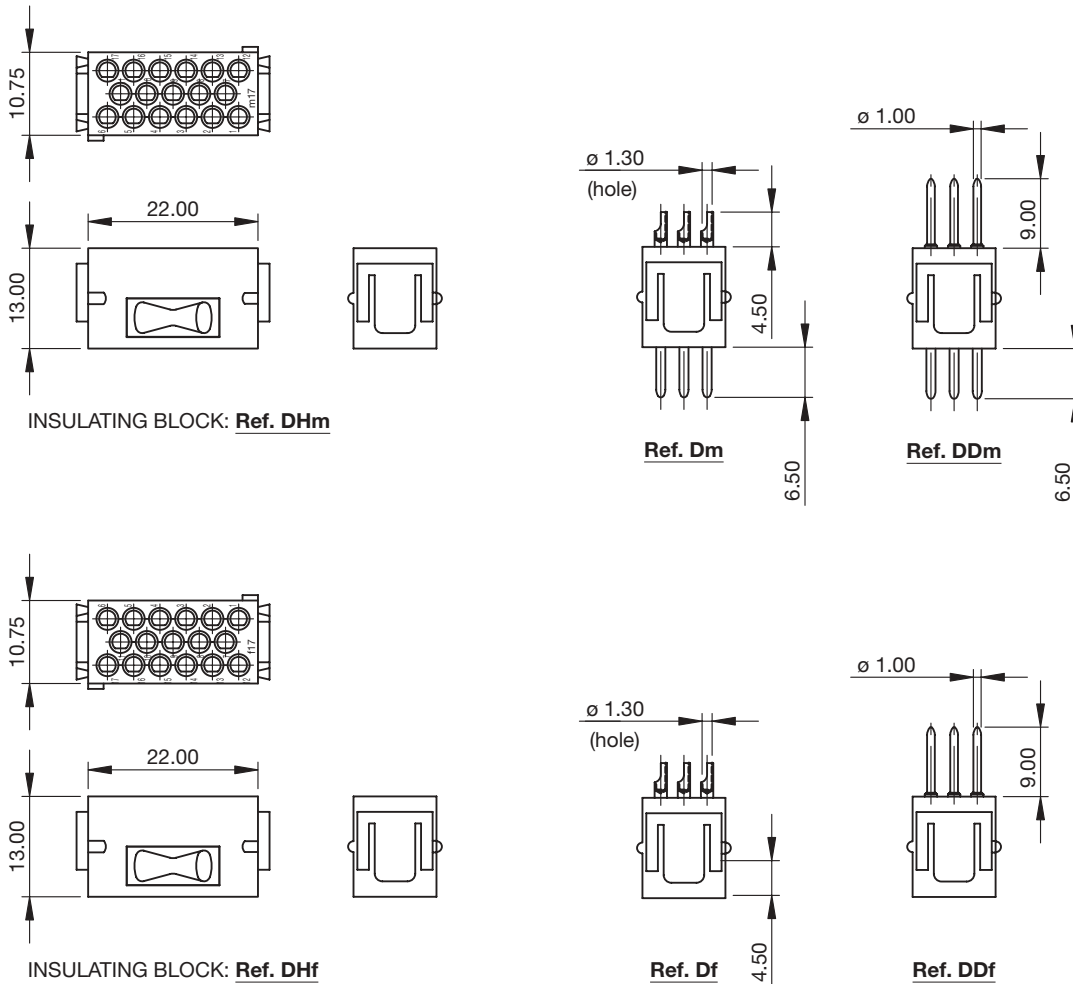
General specification

Contact Retention ¹⁾	>70 N
Mating & Unmating Force (Module) ²⁾	<19 N
Weight (M/F)	9.0/13 g
Contact Resistance (1 mA) ³⁾	<2.5 mΩ
Current Rating (25°C) ⁶⁾	9 A
Current rating at 95°C	5 A
UL Rating	8 A
Dielectric Withstanding Voltage ⁴⁾	
- Cont/ Cont	1800 V r.m.s.
- Cont/Hardware	1800 V r.m.s.
Insulation Resistance (500 V d. c.) ⁵⁾	
- Cont/ Cont	>10 ⁶ MΩ
- Cont/Hardware	>10 ⁶ MΩ
Insulator's Material	DAP

1) ref. MIL -STD-1344 Method 2007
 2) ref. MIL -STD-1344 Method 2013.1
 3) ref. MIL -STD-1344 Method 2004

4) ref. MIL -STD-1344 Method 3001.1
 5) ref. MIL -STD-1344 Method 3003.1
 6) ref. I.E.C. 512-3 Test 5b (tr=1.25/c/10xSQRT (125-T))

Type "A" element (ø 1.50 contacts)

1 STEP: 5.50mm.

(assembly with spacer clips)

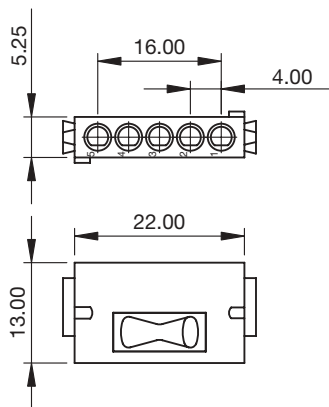

INSULATING BLOCK: **Ref. AH**

NOTE:

-The connector can be polarized ordering an element equipped with 5 plastic fitting: **Ref. AHQ**

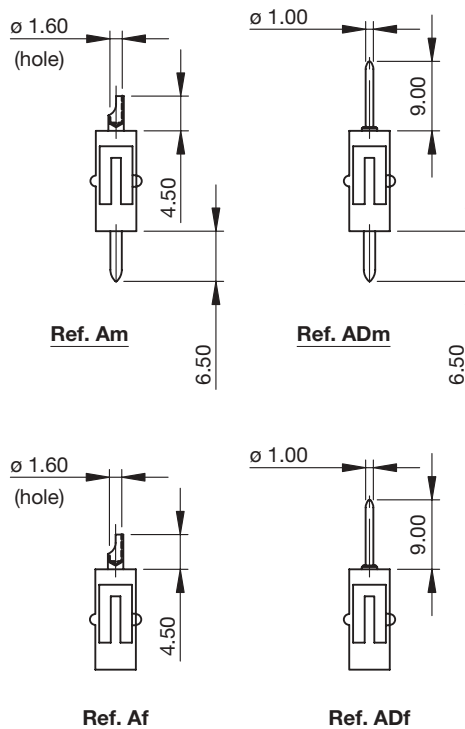

General specification

Contact Retention ¹⁾	>70 N
Mating & Unmating Force (Module) ²⁾	<7.5 N
Weight (M/F)	6.2/4.3 g
Contact Resistance (1mA) ³⁾	<2.5 mΩ
Current Rating (25°C) ⁶⁾	20 A
Current rating at 95°C	11 A
UL Rating	8 A
Dielectric Withstanding Voltage ⁴⁾	
- Cont/ Cont	2000 V r.m.s.
- Cont/Hardware	2000 V r.m.s.
Insulation Resistance (500 V d. c.) ⁵⁾	
- Cont/ Cont	>10 ⁶ MΩ
- Cont/Hardware	>10 ⁶ MΩ
Insulator's Material	DAP

1) ref. MIL -STD-1344 Method 2007
 2) ref. MIL -STD-1344 Method 2013.1
 3) ref. MIL -STD-1344 Method 2004

4) ref. MIL -STD-1344 Method 3001.1
 5) ref. MIL -STD-1344 Method 3003.1
 6) ref. I.E.C. 512-3 Test 5b (I_T= 125°C/10xSQRT (125-T))

Type "G" element (ø 1.50 contacts)
1.5 STEPS: 8.25mm.

(assembly without spacer clips)

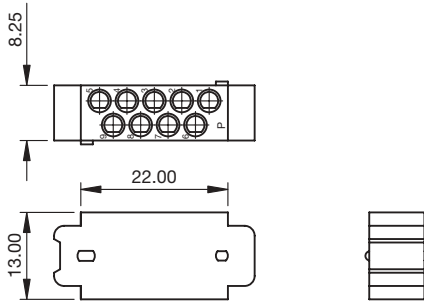
INSULATING BLOCK: Ref. GHP

For elements mounted on plug connectors

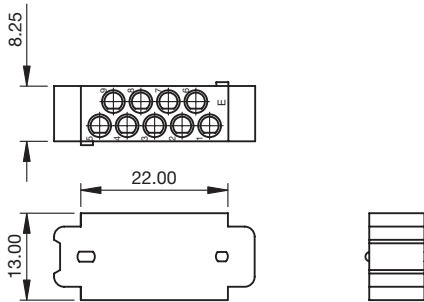
INSULATING BLOCK: Ref. GHE

For elements mounted on receptacle connectors

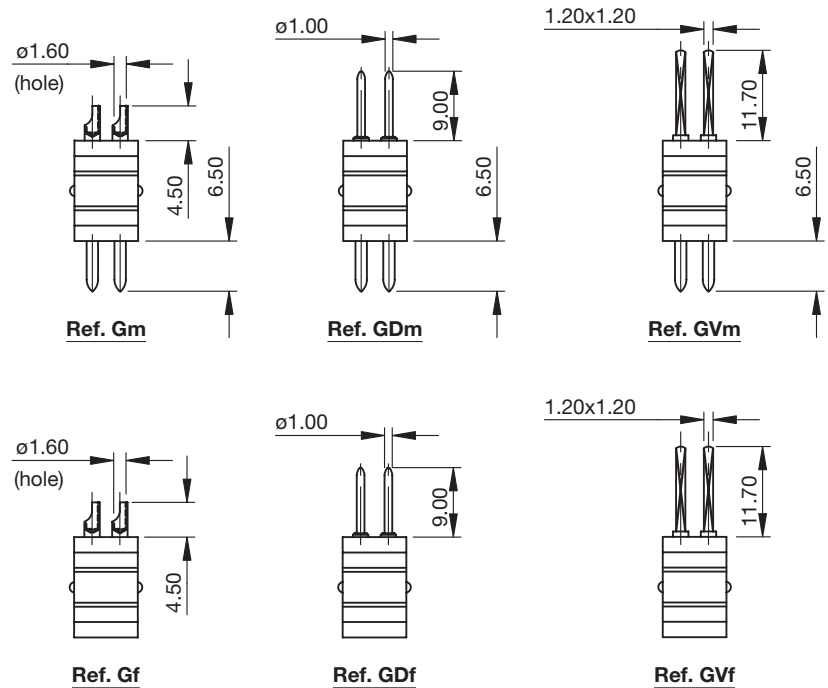
NOTES:

- The codes are for elements mounted on connectors.
- For spare elements the code must be followed by the letter P (for plug connectors) ex. GHP, GHQP, GmP, GfP, etc. E (for receptacle connectors) ex. GHE, GHQE, GmE, GfE, etc.
- The connector can be polarized ordering an element equipped with 9 plastic fittings: **Ref. GHQ**

General specification

Contact Retention ¹⁾	>70 N
Mating & Unmating Force (Module) ²⁾	<15 N
Weight (M/F)	12.2/8.9 g
Contact Resistance (1mA) ³⁾	<2.5 mΩ
Current Rating (25°C) ⁶⁾	15 A
Current rating at 95°C	8 A
UL Rating	8 A
Dielectric Withstanding Voltage ⁴⁾	
- Cont/ Cont	2000 V r.m.s.
- Cont/Hardware	1500 V r.m.s.
Insulation Resistance (500 V d. c.) ⁵⁾	
- Cont/ Cont	>10 ⁶ MΩ
- Cont/Hardware	>10 ⁶ MΩ
Insulator's Material	DAP

1) ref. MIL -STD-1344 Method 2007
2) ref. MIL -STD-1344 Method 2013.1
3) ref. MIL -STD-1344 Method 2004

4) ref. MIL -STD-1344 Method 3001.1
5) ref. MIL -STD-1344 Method 3003.1
6) ref. I.E.C. 512-3 Test 5b (I_t= 125°C/10xSQRT (125-T))

Type "X/X1" element (Ø 1.50 removable contacts-cloc)

1 STEP: 5.50mm.

(assembly without spacer clips)

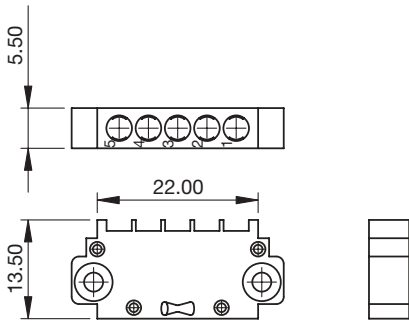

INSULATING BLOCK: **Ref. XH**

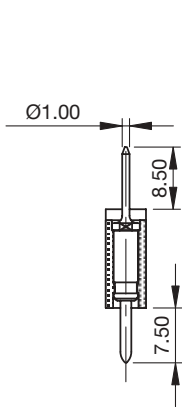

Ref. XDm

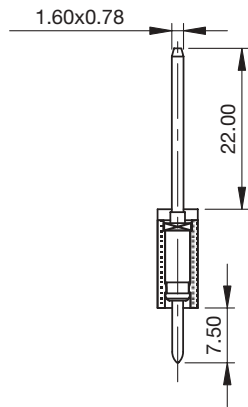

Ref. XTm

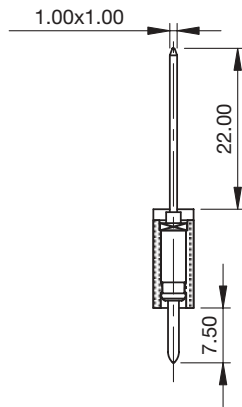

Ref. XVm

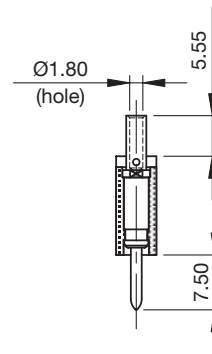

Ref. XRm (AWG 16-20)
(contacts are supplied not assembled)

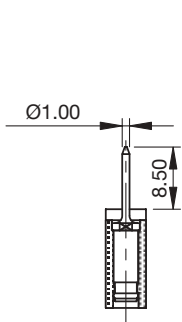

Ref. XDf

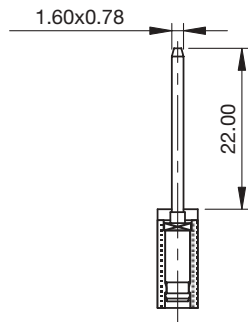

Ref. XTf

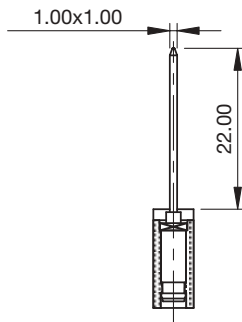

Ref. XVf

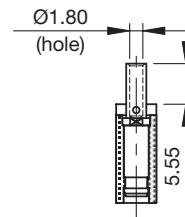

Ref. XRf (AWG 16-20)
(contacts are supplied not assembled)

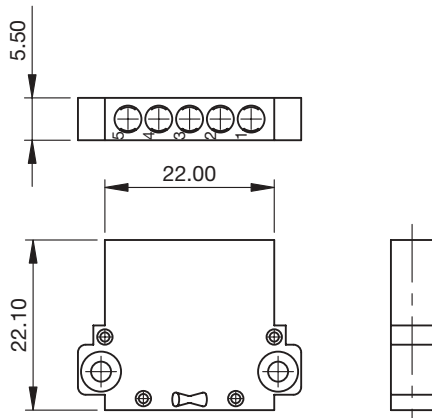
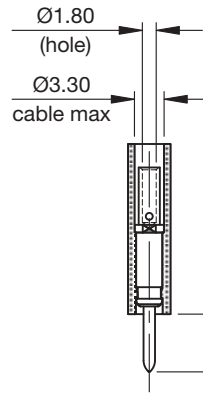
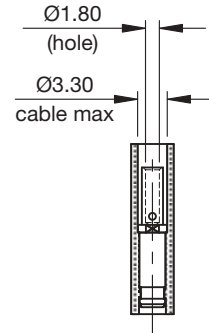
INSULATING BLOCK: Ref. XH1

Ref. XLm (AWG 16÷20)
 (contacts are supplied not assembled)

Ref. XLf (AWG 16÷20)
 (contacts are supplied not assembled)

General specification

Contact Retention ¹⁾	>40 N
Mating & Unmating Force (Module) ²⁾	<7.5 N
Weight (M/F)	6.4/4.6 g
Contact Resistance (1mA) ³⁾	<2.5 mΩ
Current Rating (25°C) ⁶⁾	15 A
Current rating at 95°C	8 A
UL Rating	8 A
Dielectric Withstanding Voltage ⁴⁾	
- Cont/ Cont	1600 V r.m.s.
- Cont/Hardware	1600 V r.m.s.
Insulation Resistance (500 V d. c.) ⁵⁾	
- Cont/ Cont	>10 ⁶ MΩ
- Cont/Hardware	>10 ⁶ MΩ
Insulator's Material	Nylon/Polycarbonate

1) ref. MIL -STD-1344 Method 2007
 2) ref. MIL -STD-1344 Method 2013.1
 3) ref. MIL -STD-1344 Method 2004

4) ref. MIL -STD-1344 Method 3001.1
 5) ref. MIL -STD-1344 Method 3003.1
 6) ref. I.E.C. 512-3 Test 5b (I_T= I_{25°C}/10×SQR (125-T))

Accessories/spare contact ref.

Insertion Tool	S-0150-01
Extraction Tool	S-0150-01
Crimping Tool	AF8
Positioner	SH463
Spare contact Pin Ref.	16480 ref. XDm 16712 ref. XTm 133-0150 ref. XVm 15947 ref. XRm/XLm
Spare contact Socket Ref.	0150-132 ref. XDf 0150-130 ref. XTf 0150-133 ref. XVf 16813 ref. XRf/XLf

Type "T" element (ø 1.50 removable contacts-clip)

1 STEP: 5.50mm.
(assembly with spacer clips)

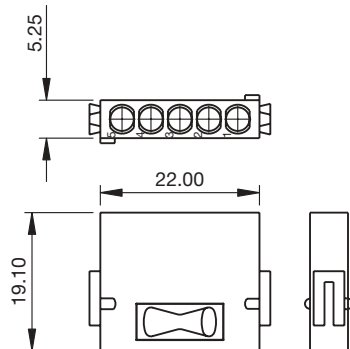

INSULATING BLOCK: **Ref. TH**

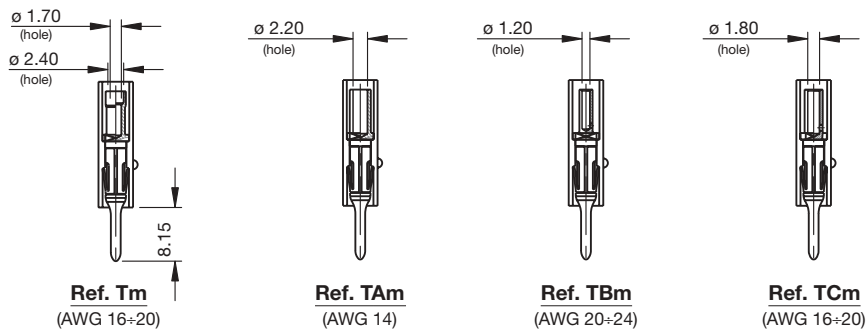

CONTACTS ARE SUPPLIED NOT ASSEMBLED

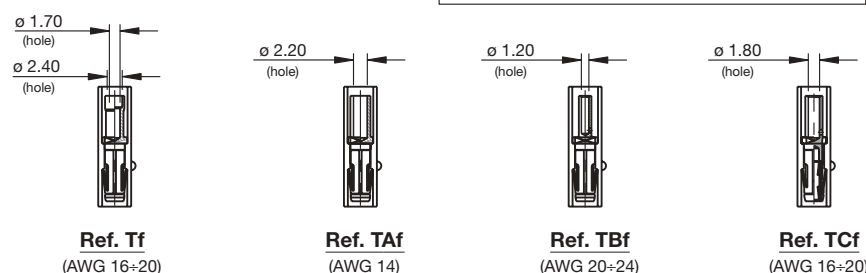

CONTACTS ARE SUPPLIED NOT ASSEMBLED

General specification

Contact Retention ¹⁾	>50 N
Mating & Unmating Force (Module) ²⁾	<17 N
Weight (M/F)	7.4/5.7 g
Contact Resistance (1mA) ³⁾	<2.5 mΩ
Current Rating (25°C) ⁶⁾	20 A
Current rating at 95°C	11 A
UL Rating	8 A
Dielectric Withstanding Voltage ⁴⁾	
- Cont/ Cont	2250 V r.m.s.
- Cont/Hardware	3000 V r.m.s.
Insulation Resistance (500 V d. c.) ⁵⁾	
- Cont/ Cont	>10 ⁶ MΩ
- Cont/Hardware	>10 ⁶ MΩ
Insulator's Material	DAP

1) ref. MIL -STD-1344 Method 2007
 2) ref. MIL -STD-1344 Method 2013.1
 3) ref. MIL -STD-1344 Method 2004
 4) ref. MIL -STD-1344 Method 3001.1
 5) ref. MIL -STD-1344 Method 3003.1
 6) ref. I.E.C. 512-3 Test 5b (Tr= 125°C/10xSQR (125-T))

Accessories/spare contact ref.

Insertion Tool	Non Necessary
Extraction Tool	15808
Crimping Tool	AF8
Positioner	15807
Spare contact Pin Ref.	15835 ref. Tm 18410 ref. TAm 18747 ref. TBm 19168 ref. TCm
Spare contact Socket Ref.	15837 ref. Tf 18412 ref. TAf 18748 ref. TBf 19171 ref. TCf

Type "N" element (ø 2.00 contacts)

4 STEPS: 22.00mm.

(assembly with spacer clips)

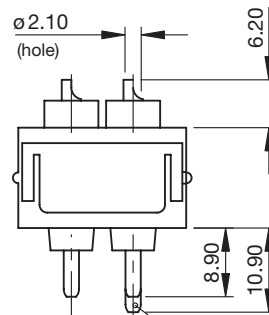
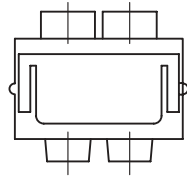
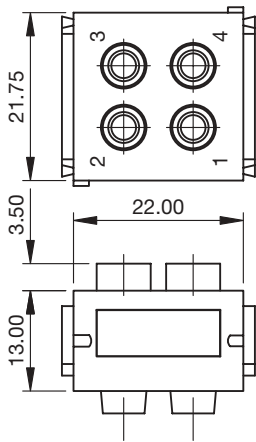

Ref. Nm

The longer contact (mate first) drawing 13327 are mounted in position 4.

INSULATING BLOCK: **Ref. NHm**

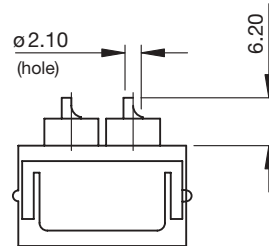
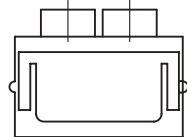
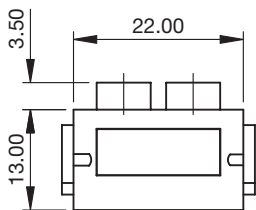
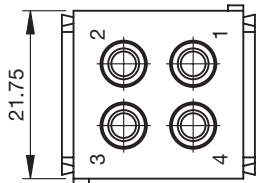

Ref. Nf

INSULATING BLOCK: **Ref. NHf**

General specification

Contact Retention ¹⁾	>70 N
Mating & Unmating Force (Module) ²⁾	<10 N
Weight (M/F)	11.5/9.5 g
Contact Resistance (1mA) ³⁾	<1.5 mΩ
Current Rating (25°C) ⁶⁾	31 A
Current rating at 95°C	17 A
UL Rating	-
Dielectric Withstanding Voltage ⁴⁾	
- Cont/ Cont	4000 V r.m.s.
- Cont/Hardware	4500 V r.m.s.
Insulation Resistance (500 V d. c.) ⁵⁾	
- Cont/ Cont	>10 ⁹ MΩ
- Cont/Hardware	>10 ⁶ MΩ
Insulator's Material	PPS

1) ref. MIL -STD-1344 Method 2007
2) ref. MIL -STD-1344 Method 2013.1
3) ref. MIL -STD-1344 Method 2004

4) ref. MIL -STD-1344 Method 3001.1
5) ref. MIL -STD-1344 Method 3003.1
6) ref. I.E.C. 512-3 Test 5b (I_T= I_{25°C}/10xSQRT (125-T))

Type "B" element (ø 2.50 contacts)

1.5 STEPS: 8.25mm.

(assembly with spacer clips)

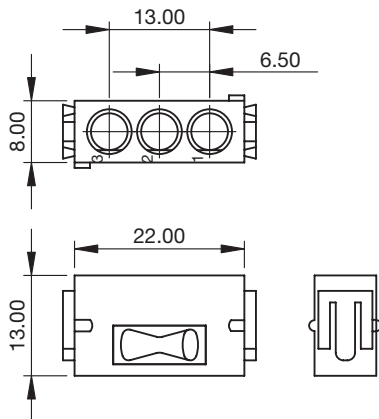

INSULATING BLOCK: **Ref. BH**

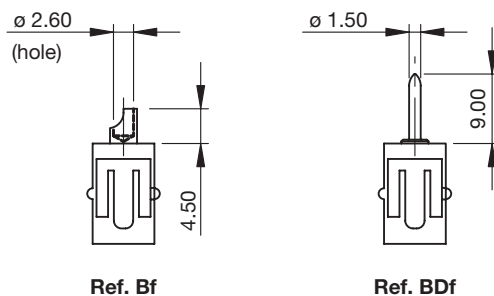
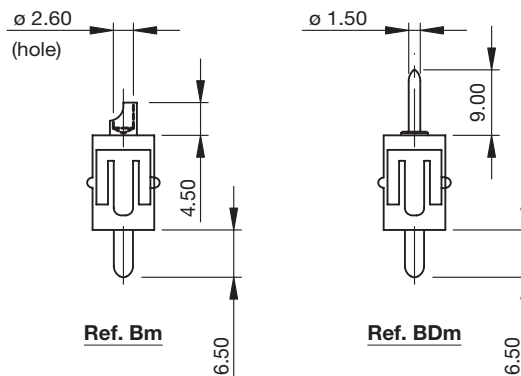

General specification

Contact Retention ¹⁾	>70 N
Mating & Unmating Force (Module) ²⁾	<17 N
Weight (M/F)	10.4/7.4 g
Contact Resistance (1mA) ³⁾	<1.0 mΩ
Current Rating (25°C) ⁶⁾	40 A
Current rating at 95°C	22 A
UL Rating	15 A
Dielectric Withstanding Voltage ⁴⁾	
- Cont/ Cont	1600 V r.m.s.
- Cont/Hardware	1600 V r.m.s.
Insulation Resistance (500 V d. c.) ⁵⁾	
- Cont/ Cont	>10 ⁶ MΩ
- Cont/Hardware	>10 ⁶ MΩ
Insulator's Material	DAP

1) ref. MIL -STD-1344 Method 2007
 2) ref. MIL -STD-1344 Method 2013.1
 3) ref. MIL -STD-1344 Method 2004
 4) ref. MIL -STD-1344 Method 3001.1
 5) ref. MIL -STD-1344 Method 3003.1
 6) ref. I.E.C. 512-3 Test 5b (I_r= I_{25°C}/10xSQRT (125-T))

Type "W" element (ø 2.50 removable contacts-cloc)

1.5 STEPS: 8.25mm.

(assembly without spacer clips)

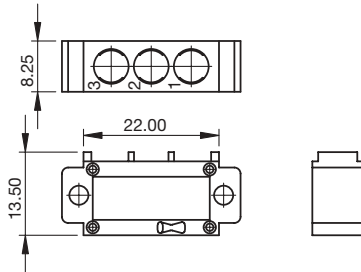

INSULATING BLOCK: **Ref. WH**

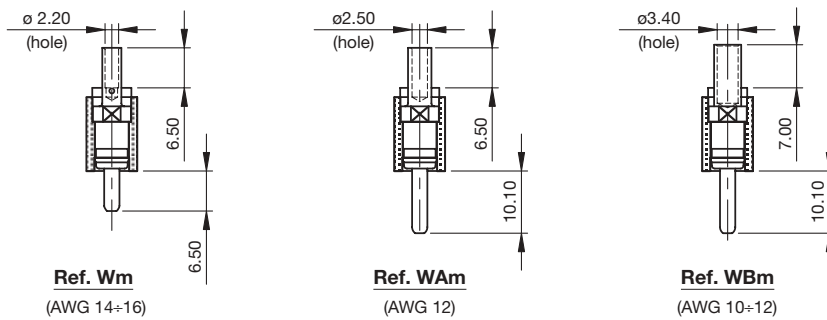

CONTACTS ARE SUPPLIED NOT ASSEMBLED

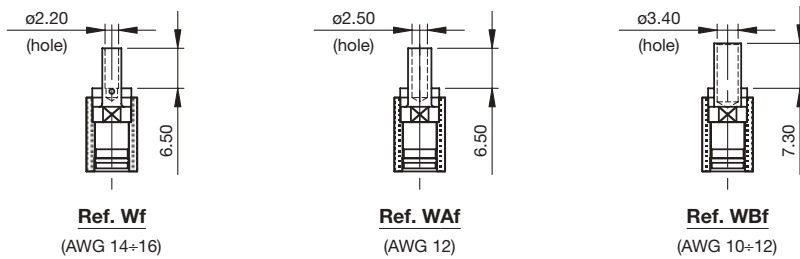

CONTACTS ARE SUPPLIED NOT ASSEMBLED

General specification

Contact Retention ¹⁾	>60 N
Mating & Unmating Force (Module) ²⁾	<7.5 N
Weight (M/F)	6.5/10 g
Contact Resistance (1mA) ³⁾	<1.0 mΩ
Current Rating (25°C) ⁶⁾	35 A
Current rating at 95°C	19 A
UL Rating	15 A
Dielectric Withstanding Voltage ⁴⁾	
- Cont/ Cont	2800 V r.m.s.
- Cont/Hardware	2800 V r.m.s.
Insulation Resistance (500 V d. c.) ⁵⁾	
- Cont/ Cont	>10 ⁶ MΩ
- Cont/Hardware	>10 ⁹ MΩ
Insulator's Material	Nylon

Accessories/spare contact ref.

Insertion Tool	S-0250-01
Extraction Tool	S-0250-01
Crimping Tool	FT8
Positioner	SH463
Spare contact Pin Ref.	12318 ref. Wm 17667 ref. WAm 19684 ref. WBm
Spare contact Socket Ref.	16825 ref. Wf 17669 ref. WAf 19683 ref. WBf

1) ref. MIL -STD-1344 Method 2007 4) ref. MIL -STD-1344 Method 3001.1
 2) ref. MIL -STD-1344 Method 2013.1 5) ref. MIL -STD-1344 Method 3003.1
 3) ref. MIL -STD-1344 Method 2004 6) ref. I.E.C. 512-3 Test 5b (I=I_{sc}/10xSQR (125-T))

Type "C and M" elements (ø 3.50 contacts)

2 STEPS: 11.00mm.

(assembly with spacer clips)

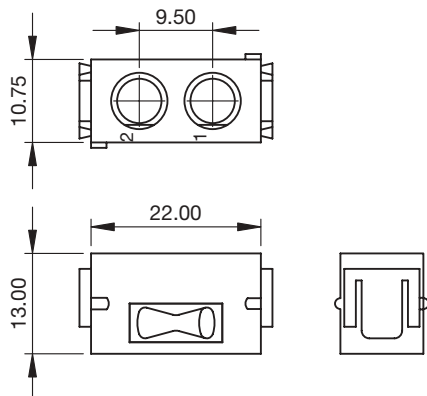

INSULATING BLOCK: **Ref. CH**

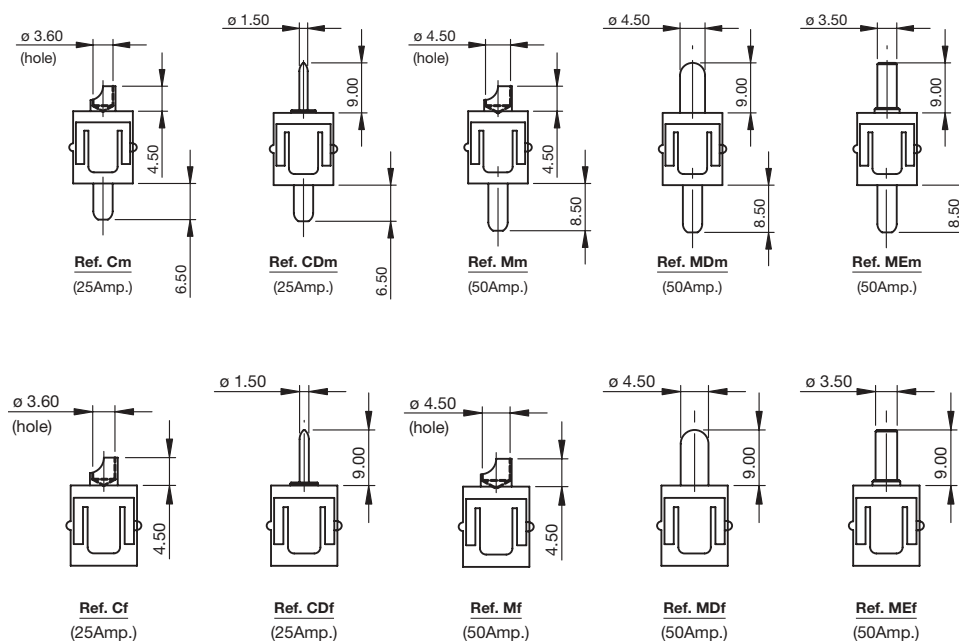

Type "C" element - General specification

Contact Retention ¹⁾	>70 N
Mating & Unmating Force (Module) ²⁾	<17 N
Weight (M/F)	12.2/8.9 g
Contact Resistance (1mA) ³⁾	<0.8 mΩ
Current Rating (25°C) ⁶⁾	57 A
Current rating at 95°C	31 A
UL Rating	25A
Dielectric Withstanding Voltage ⁴⁾	
- Cont/ Cont	2000 V r.m.s.
- Cont/Hardware	2000 V r.m.s.
Insulation Resistance (500 V d. c.) ⁵⁾	
- Cont/ Cont	>10 ⁶ MΩ
- Cont/Hardware	>10 ⁶ MΩ
Insulator's Material	DAP

Type "M" element - General specification

Contact Retention ¹⁾	>70 N
Mating & Unmating Force (Module) ²⁾	<17 N
Weight (M/F)	12/8.9 g
Contact Resistance (1mA) ³⁾	<0.6 mΩ
Current Rating (25°C) ⁶⁾	86 A
Current rating at 95°C	47 A
UL Rating	50 A
Dielectric Withstanding Voltage ⁴⁾	
- Cont/ Cont	2000 V r.m.s.
- Cont/Hardware	2000 V r.m.s.
Insulation Resistance (500 V d. c.) ⁵⁾	
- Cont/ Cont	>10 ⁶ MΩ
- Cont/Hardware	>10 ⁶ MΩ
Insulator's Material	DAP

1) ref. MIL -STD-1344 Method 2007
2) ref. MIL -STD-1344 Method 2013.1
3) ref. MIL -STD-1344 Method 2004

4) ref. MIL -STD-1344 Method 3001.1
5) ref. MIL -STD-1344 Method 3003.1
6) ref. I.E.C. 512-3 Test 5b (I_r= I_{25°C}/10xSQRT (125-T))

Type "Z" element (ø 3.50 removable contacts-cloc)

2 STEPS: 11.00mm.

(assembly without spacer clips)

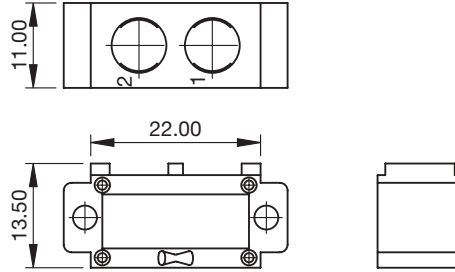
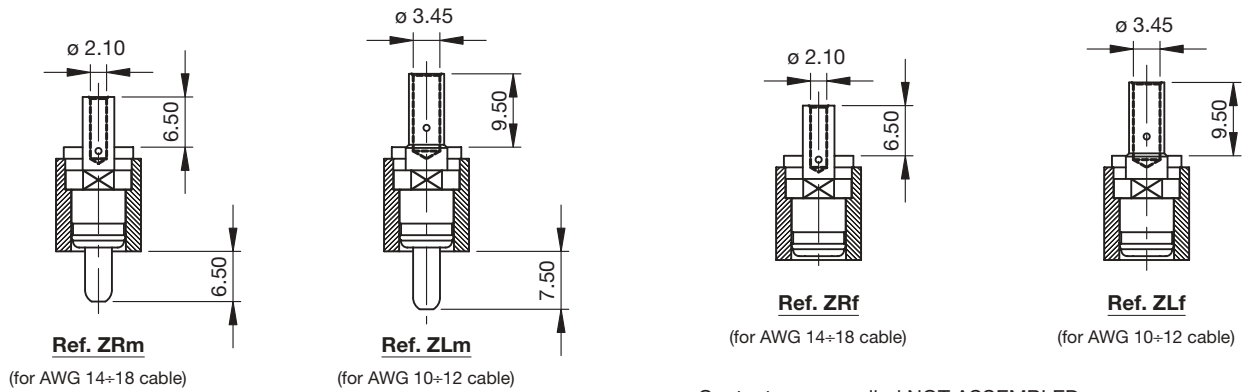
 INSULATING BLOCK: **Ref. ZH**

Contacts are supplied NOT ASSEMBLED

Contacts are supplied NOT ASSEMBLED

General specification

Contact Retention ¹⁾	>60 N
Mating & Unmating Force (Module) ²⁾	<17 N
Weight (M/F)	12/7.9 g
Contact Resistance (1mA) ³⁾	<0.8 mΩ
Current Rating (25°C) ⁶⁾	37 A
Current rating at 95°C	20 A
UL Rating	25 or 50 A
Dielectric Withstanding Voltage ⁴⁾	
- Cont/ Cont	2800 V r.m.s.
- Cont/Hardware	2800 V r.m.s.
Insulation Resistance (500 V d. c.) ⁵⁾	
- Cont/ Cont	>10 ⁶ MΩ
- Cont/Hardware	>10 ⁶ MΩ
Insulator's Material	Nylon

1) ref. MIL -STD-1344 Method 2007
 2) ref. MIL -STD-1344 Method 2013.1
 3) ref. MIL -STD-1344 Method 2004

4) ref. MIL -STD-1344 Method 3001.1
 5) ref. MIL -STD-1344 Method 3003.1
 6) ref. I.E.C. 512-3 Test 5b (I_{tr}= I_{25°C}/10xSQRT (125-T))

Accessories/spare contact ref.

Insertion Tool	S-0350-01
Extraction Tool	S-0350-01
Crimping Tool	M310
Positioner	TP999
Spare contact Pin Ref.	12320 ref. ZRm 16600 ref. ZLm
Spare contact Socket Ref.	16722 ref. ZRf 16601 ref. ZLf

Type "Z" element (ø 3.50 removable contacts-clip)

2 STEPS: 11.00mm.

(assembly without spacer clips)

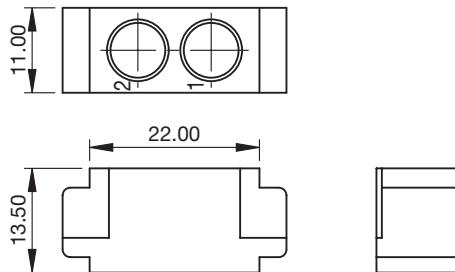

INSULATING BLOCK: **Ref. ZH1**

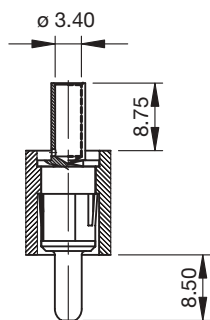

Ref. ZAm

(for AWG 10÷12 cable)

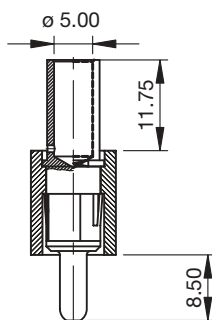

Ref. ZBm

(for 10mm² cable.)

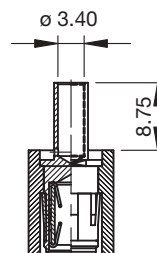

Ref. ZAf

(for AWG 10÷12 cable)

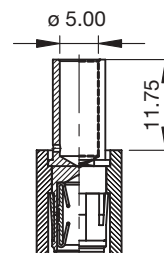

Ref. ZBf

(for 10mm² cable.)

General specification

Contact Retention ¹⁾	>60 N
Mating & Unmating Force (Module) ²⁾	<17 N
Weight (M/F)	12/7.9 g
Contact Resistance (1mA) ³⁾	<0.8 mΩ
Current Rating (25°C) ⁶⁾	37 A
Current rating at 95°C	20 A
UL Rating	25 or 50 A
Dielectric Withstanding Voltage ⁴⁾	
- Cont/ Cont	2800 V r.m.s.
- Cont/Hardware	2800 V r.m.s.
Insulation Resistance (500 V d. c.) ⁵⁾	
- Cont/ Cont	>10 ⁶ MΩ
- Cont/Hardware	>10 ⁶ MΩ
Insulator's Material	Nylon

1) ref. MIL -STD-1344 Method 2007
2) ref. MIL -STD-1344 Method 2013.1
3) ref. MIL -STD-1344 Method 2004

4) ref. MIL -STD-1344 Method 3001.1
5) ref. MIL -STD-1344 Method 3003.1
6) ref. I.E.C. 512-3 Test 5b (I_{tr}= I_{25°C}/10xSQRT (125-T))

Accessories/spare contact ref.

Insertion Tool	Not Necessary
Extraction Tool	20267
Crimping Tool	M310/WA23
Positioner	TP1290/M0601
Spare contact Pin Ref.	18972 ref. ZAm 19398 ref. ZBm
Spare contact Socket Ref.	16829 ref. ZAf 19395 ref. ZBf

Type "I" element (ø 6.00 contacts)

4 STEPS: 22.00mm.

(assembly without spacer clips)

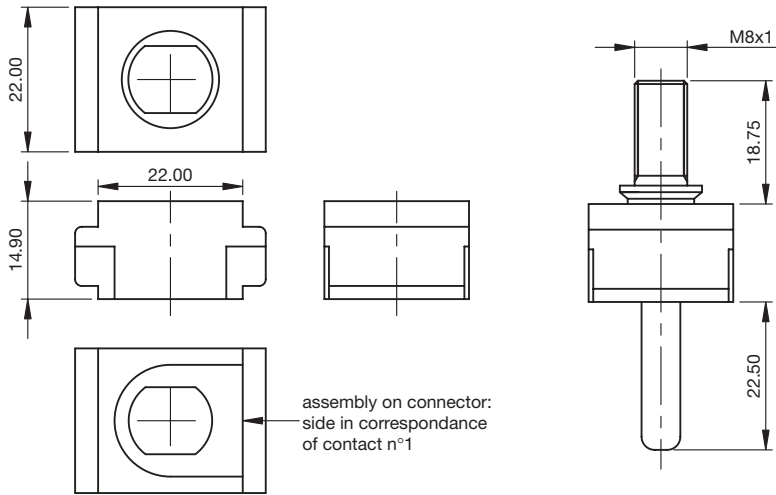
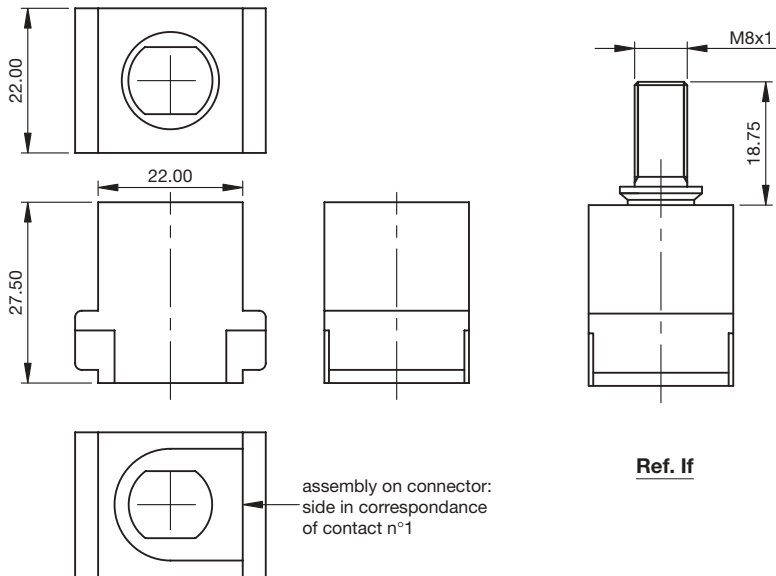
 INSULATING BLOCK: **Ref. IHm**
Ref. Im

 INSULATING BLOCK: **Ref. IHf**
Ref. If
General specification

Contact Retention ¹⁾	>100 N
Mating & Unmating Force (Module) ²⁾	<20 N
Weight (M/F)	40/50 g
Contact Resistance (1mA) ³⁾	< 0.3 mΩ
Current Rating (25°C) ⁶⁾	200 A
Current rating at 95°C	100 A
UL Rating	-
Dielectric Withstanding Voltage ⁴⁾	
- Cont/ Cont	250 V r.m.s.
- Cont/Hardware	250 V r.m.s.
Insulation Resistance (500 V d. c.) ⁵⁾	
- Cont/ Cont	>10 ⁶ MΩ
- Cont/Hardware	>10 ⁶ MΩ
Insulator's Material	Nylon

1) ref. MIL -STD-1344 Method 2007

4) ref. MIL -STD-1344 Method 3001.1

2) ref. MIL -STD-1344 Method 2013.1

5) ref. MIL -STD-1344 Method 3003.1

3) ref. MIL -STD-1344 Method 2004

 6) ref. I.E.C. 512-3 Test 5b (I_T= I_{25°C}/10xSQRT (125-T))

For spare parts ordering codes: consult factory

Dimensions are in mm

Type “E” element (shielded contacts)

2 STEPS: 11.00mm.

(assembly with spacer clips)

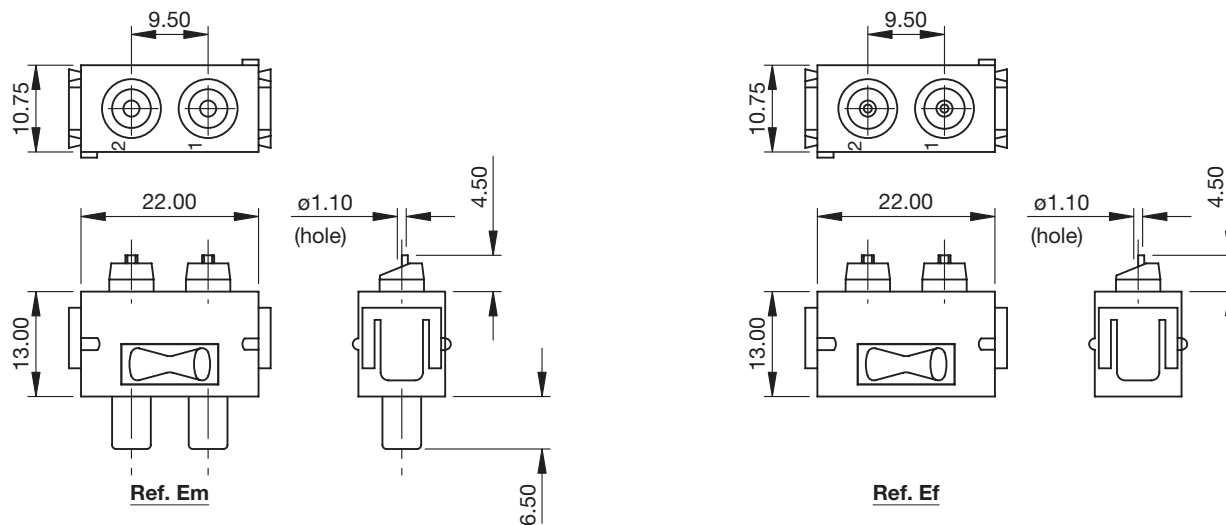

General specification

Contact Retention ¹⁾	n/a
Mating & Unmating Force (Module) ²⁾	<40 N
Weight (M/F)	15/10.2 g
Contact Resistance (1mA) ³⁾	<4 mΩ (inner), <0.6 mΩ (outer)
Current Rating (25°C) ⁶⁾	9 A
Current rating at 95°C	5 A
UL Rating	-
Dielectric Withstanding Voltage ⁴⁾	
- Cont/ Cont	1300 V r.m.s.
- Cont/Hardware	2500 V r.m.s.
Insulation Resistance (500 V d. c.) ⁵⁾	
- Cont/ Cont	>10 ⁶ MΩ
- Cont/Hardware	>10 ⁶ MΩ
Insulator's Material	DAP

1) ref. MIL -STD-1344 Method 2007
 2) ref. MIL -STD-1344 Method 2013.1
 3) ref. MIL -STD-1344 Method 2004
 4) ref. MIL -STD-1344 Method 3001.1
 5) ref. MIL -STD-1344 Method 3003.1
 6) ref. I.E.C. 512-3 Test 5b (I_{tr}= I_{25°C}/10xSQRT (125-T))

Type "H" element (high voltage contacts)

2 STEPS: 11.00MM.

(assembly with spacer clips)

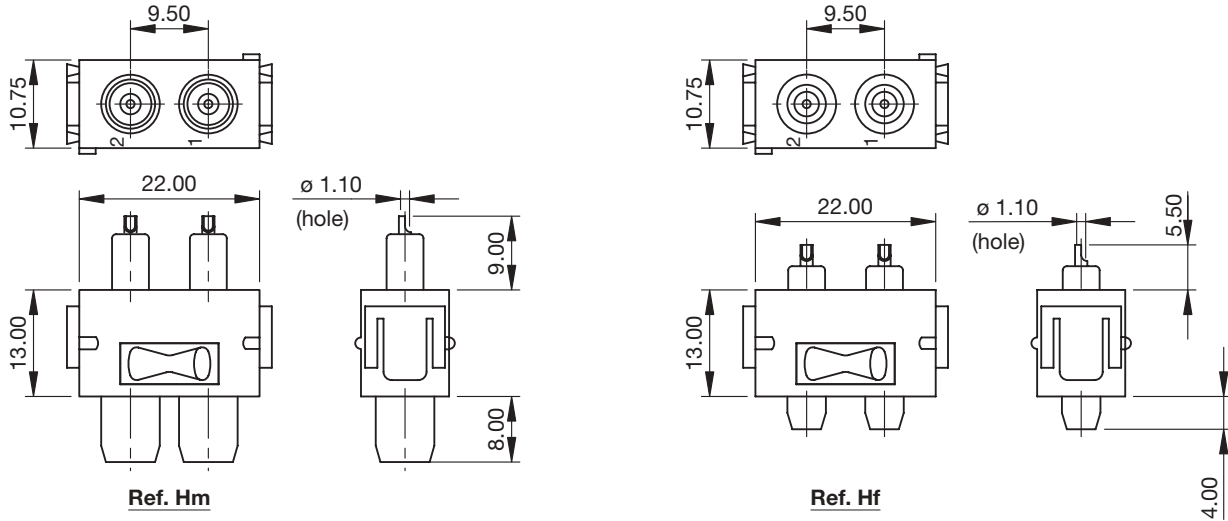
General specification

Contact Retention ¹⁾	>70 N
Mating & Unmating Force (Module) ²⁾	<20 N
Weight (M/F)	7.4/5.8 g
Contact Resistance (1mA) ³⁾	<3.5 m Ω
Current Rating (25°C) ⁶⁾	9 A
Current rating at 95°C	5 A
UL Rating	-
Dielectric Withstanding Voltage ⁴⁾	
- Cont/ Cont	8000 V r.m.s.
- Cont/Hardware	8000 V r.m.s.
Insulation Resistance (500 V d. c.) ⁵⁾	
- Cont/ Cont	>10 ⁶ M Ω
- Cont/Hardware	>10 ⁶ M Ω
Insulator's Material	DAP

1) ref. MIL -STD-1344 Method 2007

2) ref. MIL -STD-1344 Method 2013.1

3) ref. MIL -STD-1344 Method 2004

4) ref. MIL -STD-1344 Method 3001.1

5) ref. MIL -STD-1344 Method 3003.1

6) ref. I.E.C. 512-3 Test 5b (I_r= I_{25°C}/10xSQRT (125-T))

Type "L" element (coaxial contacts) (consult factory)

1.5 STEPS: 8,25mm.

(assembly with spacer clips)

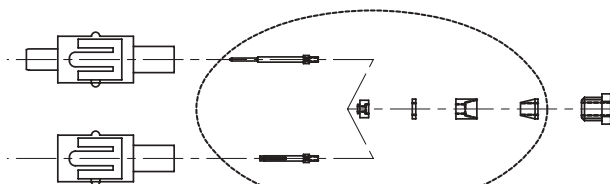
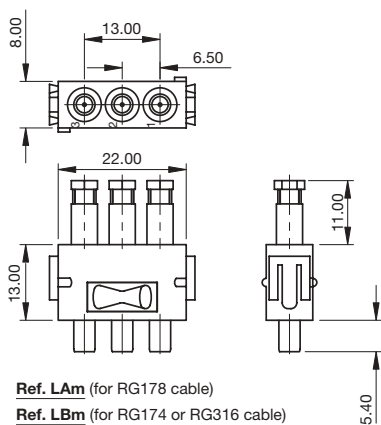

NOTE:
- Assembly instructions as per drawing 15073.

Items to be supplied not assembled in package (ex. nylon bag) for each single element.

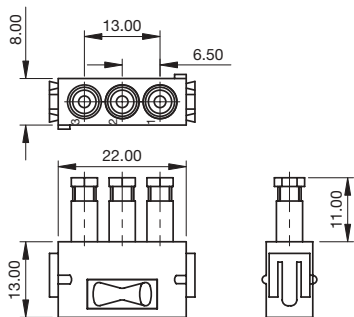

Ref. LAf (for RG178 cable)
Ref. LBf (for RG174 or RG316 cable)

General specification

Contact Retention ¹⁾	>40 N
Mating & Unmating Force (Module) ²⁾	<20 N
Weight (M/F)	8.9/11 g
Contact Resistance (1mA) ³⁾	<2.5 mΩ
Dielectric Withstanding Voltage ⁴⁾	
- Inner Cont/Outer Cont	1000 V r.m.s.
- Outer Cont/Hardware	1500 V r.m.s.
Insulation Resistance (500 V d. c.) ⁵⁾	
- Inner Cont/Outer Cont	>10 ⁶ MΩ
- Outer Cont/Hardware	>10 ⁶ MΩ
Standing Wave ratio (3.9 GHz) ⁶⁾	<1.1
Impedance	50 Ω
Insulator's Material	DAP

1) ref. MIL -STD-1344 Method 2007
2) ref. MIL -STD-1344 Method 2013.1
3) ref. MIL -STD-1344 Method 2004

4) ref. MIL -STD-1344 Method 3001.1
5) ref. MIL -STD-1344 Method 3003.1
6) ref. MIL -STD-1344 Method 3005

Type "J" element (coaxial contacts)

2 STEPS: 11.00mm.

(assembly with spacer clips)

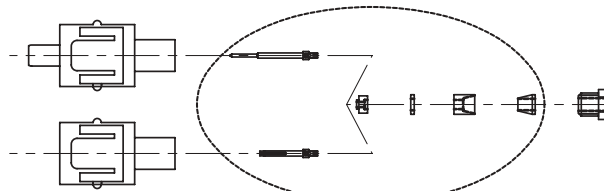
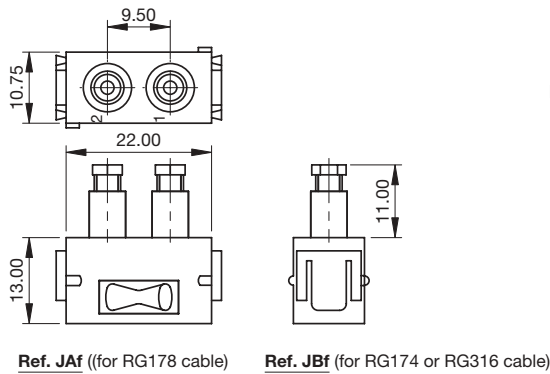
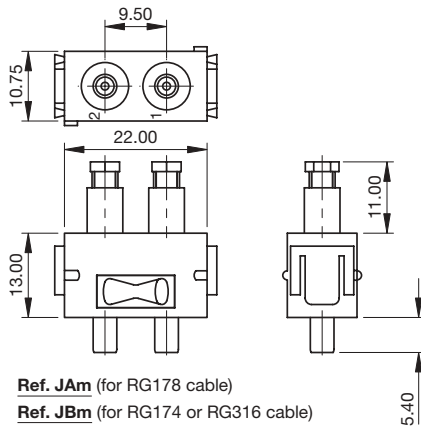

NOTE:
 - Assembly instructions as per drawing 15073.

Items to be supplied not assembled in package (ex. nylon bag) for each single element.

General specification

Contact Retention ¹⁾	>70 N
Mating & Unmating Force (Module) ²⁾	<13 N
Weight (M/F)	11.5/12.8 g
Contact Resistance (1mA) ³⁾	<2.5 mΩ
Dielectric Withstanding Voltage ⁴⁾	
- Inner Cont/Outer Cont	1000 V r.m.s.
- Outer Cont/Hardware	1000 V r.m.s.
Insulation Resistance (500 V d. c.) ⁵⁾	
- Inner Cont/Outer Cont	>10 ⁶ MΩ
- Outer Cont/Hardware	>10 ⁶ MΩ
Standing Wave ratio (3.9 GHz) ⁶⁾	<1.1
Impedance	50 Ω
Insulator's Material	DAP

1) ref. MIL -STD-1344 Method 2007
 2) ref. MIL -STD-1344 Method 2013.1
 3) ref. MIL -STD-1344 Method 2004

4) ref. MIL -STD-1344 Method 3001.1
 5) ref. MIL -STD-1344 Method 3003.1
 6) ref. MIL -STD-1344 Method 3005

Type "K" element (coaxial contacts)

2 STEPS: 11.00mm.

(assembly with spacer clips)

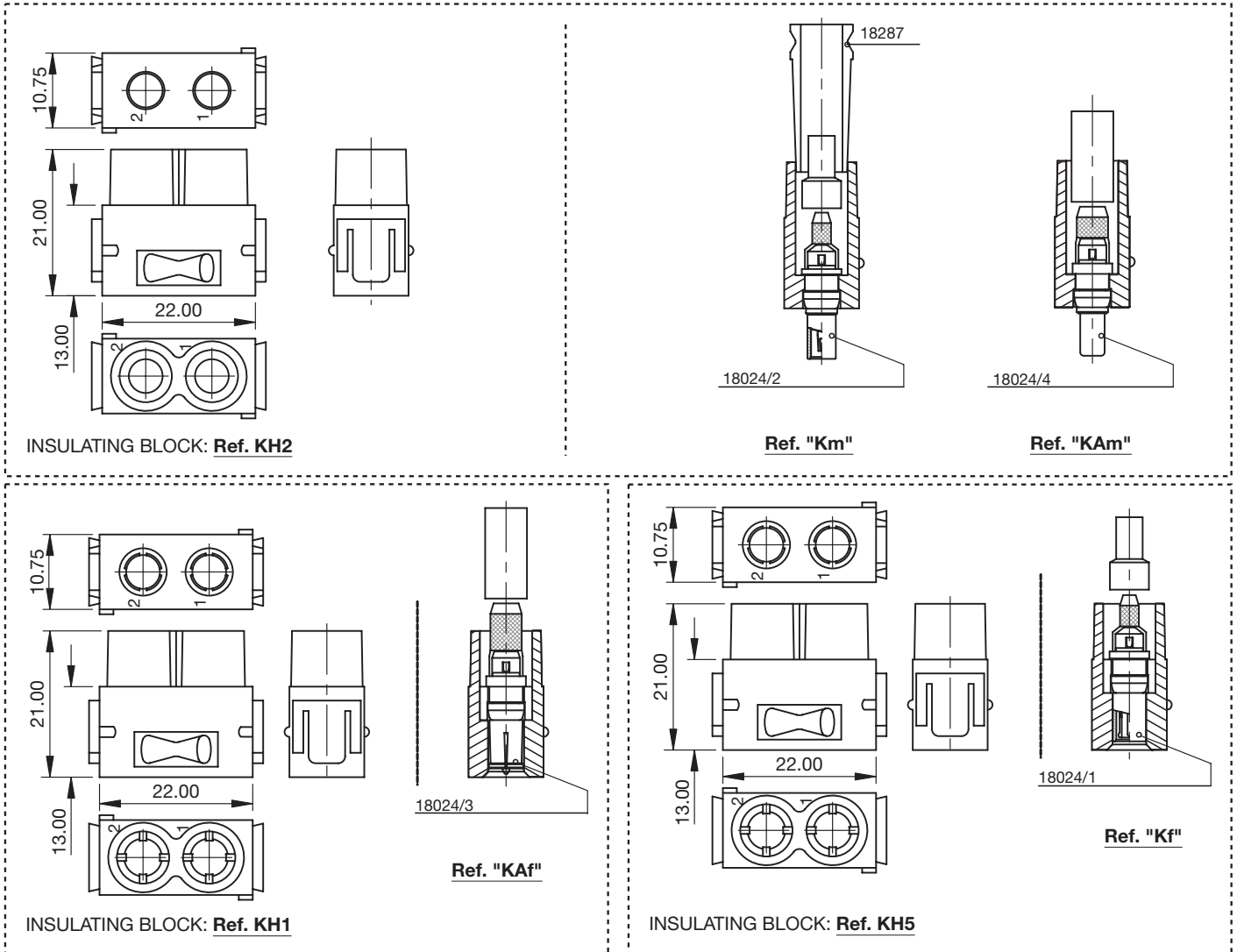

General specification

Contact Retention ¹⁾	>40 N
Mating & Unmating Force (Module) ²⁾	<15 N
Weight (M/F)	7.0/7.2 g
Contact Resistance (1mA) ³⁾	<5.0 mΩ
Dielectric Withstanding Voltage ⁴⁾	
- Inner Cont/Outer Cont	1000 V r.m.s.
- Outer Cont/Hardware	2000 V r.m.s.
Insulation Resistance (500 V d. c.) ⁵⁾	
- Inner Cont/Outer Cont	>10 ⁶ MΩ
- Outer Cont/Hardware	>10 ⁶ MΩ
Standing Wave ratio (3.9 GHz) ⁶⁾	<1.2
Impedance	50 Ω *
Insulator's Material	DAP

Accessories

Ref.	18024/1	18024/2	18024/3	18024/4
Cable	RG316/RG174	RG316/RG174	RG58	RG58
Crimping tool	M0576	M0576	M0576	M0576
Positioner	M0577	M0577	11W.150.106	11W.150.106
Extraction tool	M0578	M0578	11W.101.000	11W.101.000

1) ref. MIL -STD-1344 Method 2007
 2) ref. MIL -STD-1344 Method 2013.1
 3) ref. MIL -STD-1344 Method 2004

4) ref. MIL -STD-1344 Method 3001.1
 5) ref. MIL -STD-1344 Method 3003.1
 6) ref. MIL -STD-1344 Method 3005

* 75Ω also available. Ask factory.

Type "Y" element (for fiber optic couplers)

2 STEPS: 11.00mm.

(assembly with spacer clips)

view of assemble contact

INSULATING BLOCK: **Ref. YHm (KH4)**
Made for male fiber optic couplers

view of assemble contact

INSULATING BLOCK: **Ref. YHf (KH3)**
Made for female fiber optic couplers

view of assemble contact

INSULATING BLOCK: **Ref. YHAm (KH2)**
Made for male fiber optic couplers according to DIN 41626

view of assemble contact

INSULATING BLOCK: **Ref. YHAf (KH5)**
Made for female fiber optic couplers according to DIN 41626

Type "O" Jackscrew

PLUG side connector

2 STEPS: 11.00mm.

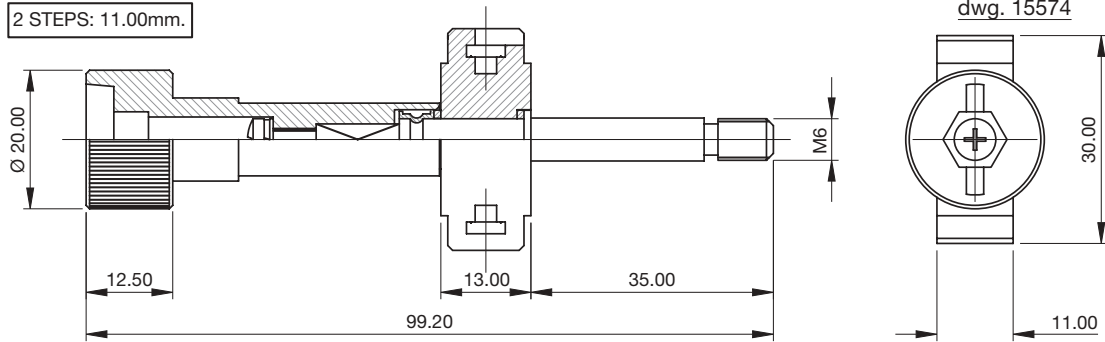

RECEPTACLE side connector

2 STEPS: 11.00mm.

dwg. 15953

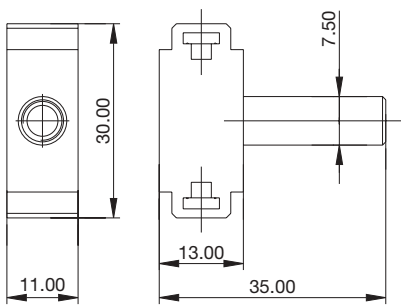

NOTE

Preferred for "BV" series

Type "2" Jackscrew

PLUG side connector

2 STEPS: 11.00mm.

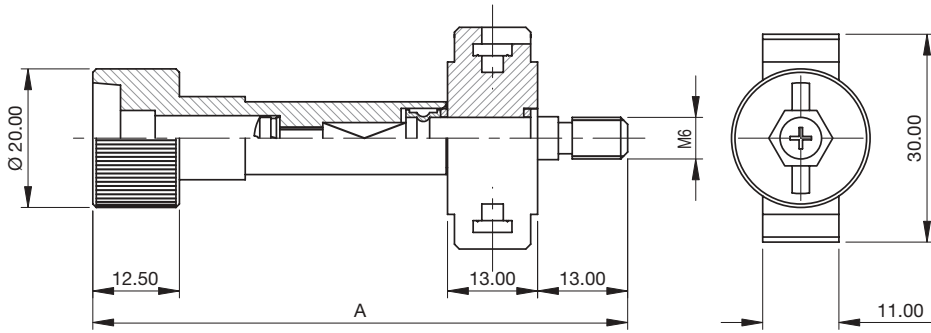

Application	A	Ref. Dwg
All series	77.20	15373
Series V 2 cable clamps	90.20	15374

RECEPTACLE side connector

2 STEPS: 11.00mm.

dwg. 15301

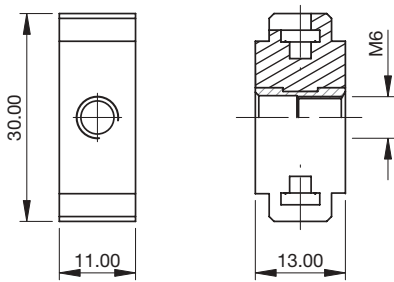

Panel cutout

Type: PA-EA-PB-EB-EJ-EK

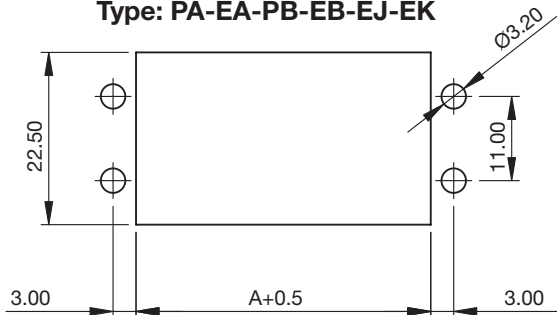

Type: PBV- EBV-EJV-EKV

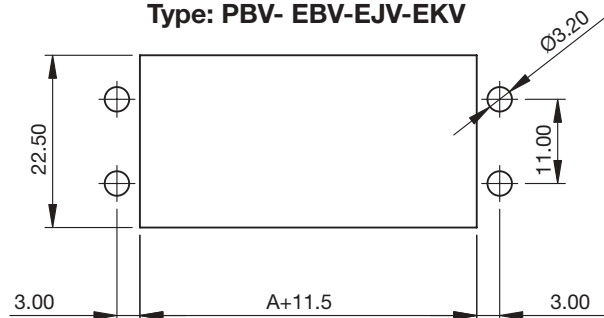

Type: PH

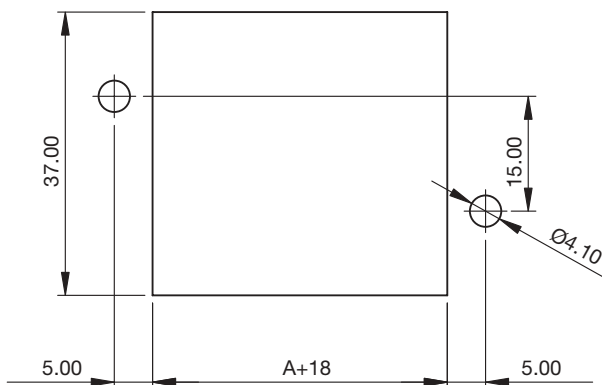

Type: EH

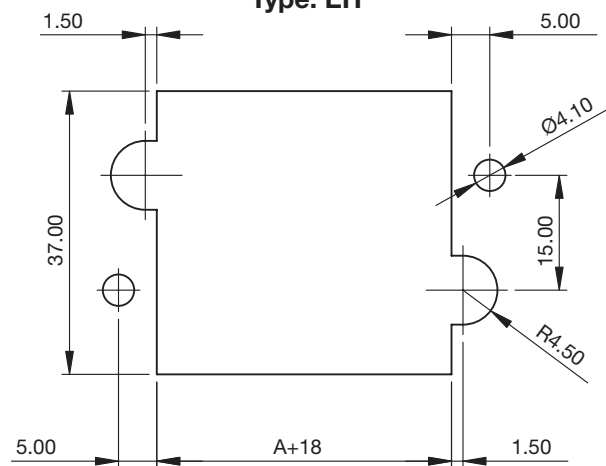

Type: EVO

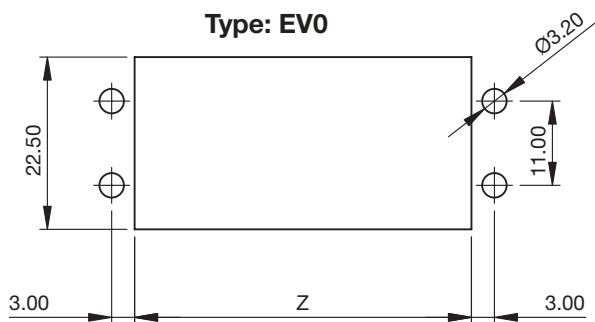

EVO length-indication "a": Z= 66.5
 EVO length-indication "b": Z= 83.0
 EVO length-indication "c": Z= 83.0
 EVO length-indication "d": Z= 94.0
 EVO length-indication "e": Z= 110.5
 EVO length-indication "f": Z= 121.5

Type: EV1

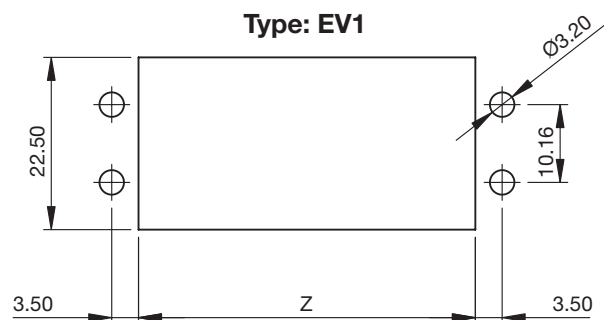

EV1 length-indication "a": Z= 66.5
 EV1 length-indication "b": Z= 83.0
 EV1 length-indication "c": Z= 83.0
 EV1 length-indication "d": Z= 94.0
 EV1 length-indication "e": Z= 110.5
 EV1 length-indication "f": Z= 121.5

Advanced Solutions for Every Application



Military and Aerospace

Hypertac is a major supplier of interconnect products to the world's leading civil and military aerospace manufacturers. From civil airlines to new generation strike fighter aircrafts, Hypertac connector solutions are used extensively on all systems where reliability is a must.



Medical

Medical applications cannot accept any form of compromise on performance or quality: the stakes are far too high when life is involved. That's why Hypertac products are used extensively in areas where integrity is essential to the well being of the patient.

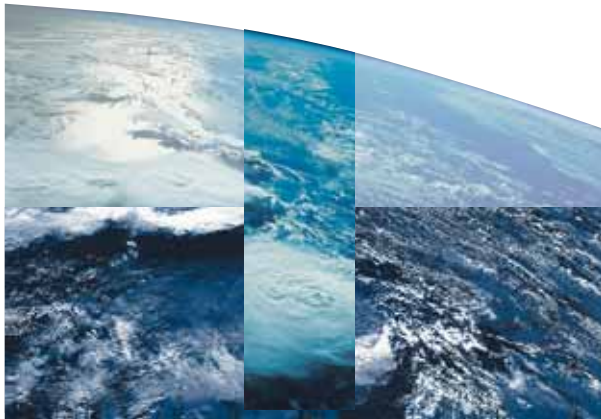

Space

From satellites to rocket launchers, Hypertac offers a range of ESA approved connectors delivering the essential quality, reliability, and longevity of operation that are required for such demanding applications.

Test and Measurement

Test equipment applications rely on the integrity of the components used within them. Hypertac custom modular connectors ensure superior longevity and extremely low mating forces even when using a high connection count.



Mass Transit

Hypertac experience in signal and power connectors for the rail traction results in customer-driven, reliable solutions with an easy use and unlimited application possibilities. Hypertac products conform to the main international standards and have earned the trust of the railways industry.

Industrial

Industrial and machine tool product applications demand top quality interconnect systems at the lowest possible cost. Hypertac products offer a low cost of ownership associated with high quality and reliable performance even in the harshest environments.



GLOBAL SALES OFFICES

Europe

Hypertac S.A.

31 rue Isidore Maille,
76410 St. Aubin Lès Elbeuf, France
t: +33 (0) 2 32969176
f: +33 (0) 2 32969170
e: info@hypertac.fr

Hypertac GmbH

Ulrichsberger Straße 17,
94469 Deggendorf, Germany
t: +49 (0) 991 250120
f: +49 (0) 991 2501244
e: info@hypertac.de

Hypertac SpA

Via P.D. Da Bissone 7A,
16153 Genova-Sestri P., Italy
t: +39 0 10 60361
f: +39 0 10 6036280
e: info@hypertac.it

Hypertac Limited

36, Waterloo Road,
London NW2 7UH, UK
t: +44 (0) 20 8450 8033
f: +44 (0) 20 8208 4114
e: info@hypertac.co.uk

America

Hypertronics Corporation

16 Brent Drive, Hudson,
MA 01749-2978, USA
t: +1 (0) 978 5680451
f: +1 (0) 978 5680680
e: info@hypertronics.com

Asia

Hypertac China

Unit F1, 7th Floor,
East Ocean Center Phase II,
No. 618, Yan'An Road East,
Shanghai, China, 200001
t: +86 21 3318 4650
f: +86 21 5385 4506
e: info@hypertac.fr

Hypertac Japan

Toward-senju No.1, 801, Senju 3-6,
Adachi, Tokyo, Japan, 120-0034
t: +81 3 3870 8205
f: +81 3 3870 8264
e: info.japan@hypertac.it

Hypertac India

c/o John Crane
Sealing Systems India Pvt. Ltd.,
No. 707, Hemkunt Tower,
98, Nehru Place,
New Delhi 110019, India
t: +91 9818990907
f: +91 11 26443941
e: info@hypertac.fr

Hypertac India

c/o John Crane
Sealing Systems India Pvt. Ltd.
No.11, 1st Phase Peenya
Industrial Area,
Bangalore 560058, India
t: +91 80 2839 2200
f: +91 80 2839 8205/06
e: info@hypertac.fr



FOR FURTHER INFORMATION VISIT www.hypertac.com

Distributor